

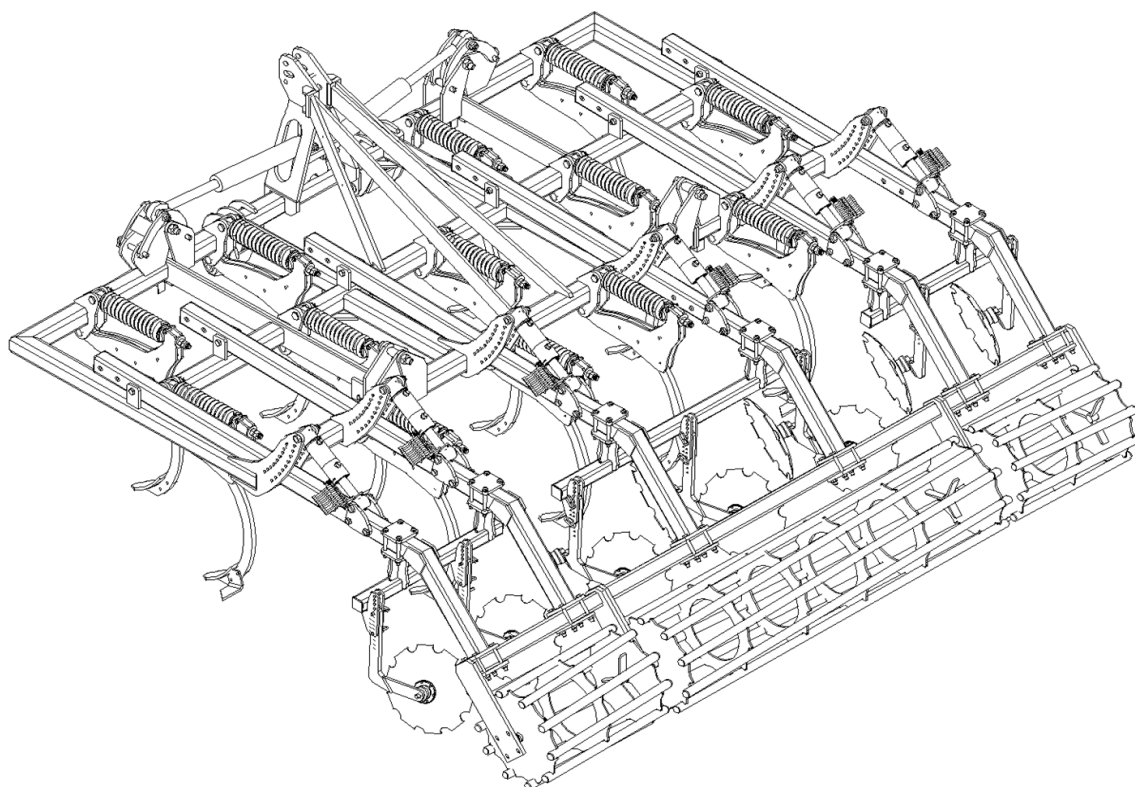

MANDAM Sp. z o.o.
44-100 Gliwice ul. Toruńska 14
e-mail mandam@mandam.com.pl
Phone: +48 32 232 26 60 Fax: 032 232 58 85
TIN: 648 000 16 74 REGON (statistical No.): P - 008173131

OPERATION MANUAL

SPEC HD CULTIVATOR



Revision II
Gliwice 2023



EC DECLARATION OF CONFORMITY



FOR THE MACHINE

*Pursuant to the Ordinance of the Minister of Economy of 21 October 2008 (Journal of Laws No. 199, item 1228)
and the Directive of the European Union 2006/42/EC of 17 May 2006*

MANDAM Sp. z o.o.

ul. Toruńska 14

44 -100 Gliwice

declares with full responsibility that the machine:

SPEC HD CULTIVATOR

type/model
serial No.
year of production

under this declaration, complies with:

Ordinance of the Ministry of Economy of October 21, 2008 on the essential requirements for machines (Journal of Laws No. 199, item 1228) and **Directive** of the European Union 2006/42/EC of 17 May 2006

Persons responsible for the technical documentation of the machine: Jarosław Kudlek, Łukasz

Jakus

ul. Toruńska 14, 44-100 Gliwice

The following standards were also used to assess compliance:

PN-EN ISO 13857:2010,
PN-EN ISO 4254-1:2016-02,
PN-EN ISO 12100-1:2005/A1:2012
PN-EN ISO 12100-2:2005/A1:2012
PN-EN 982+A1:2008

This EC Declaration of Conformity loses its validity, if the machine is modified or converted without the manufacturer's consent.

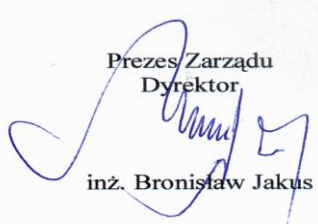
Prezes Zarządu
Dyrektor

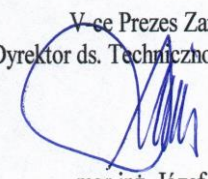
inż. Bronisław Jakus

V-ce Prezes Zarządu
Dyrektor ds. Techniczno-Organizacyjnych

mgr inż. Józef Seidel

.....
Place and date of issue

.....
Surname, first name, position
and signature of the authorized person

1.	Introduction.....	4
1.1.	Safety signs and inscriptions	5
2.	General information	7
2.1.	Construction of the SPEC HD cultivator	7
3.	General safety rules.....	8
3.1.	Proper coupling and uncoupling of the machine to/from the tractor	9
3.2.	Tyres	9
3.3.	Hydraulic and pneumatic system	9
3.4.	Safety regarding transport on public roads.....	10
3.5.	Description of residual risk	10
3.6.	Assessment of residual risk	10
4.	Information on handling and use	11
4.1.	Preparing the cultivator for work	12
4.2.	Coupling the cultivator to the tractor	14
4.3.	Operation and adjustment.....	15
4.3.1.	Side arms adjustment	15
4.3.2.	Working depth adjustment	17
4.4.	Rules for transporting the cultivator on public roads and lighting the machine	20
4.5.	Maintenance and lubrication	21
4.6.	Screw tightening torque.....	22
5.	Everyday service	23
5.1.	Out-of-season handling and storage	24
5.1.1.	Operation of the hydraulic system	24
5.1.2.	SPEC HD running system handling (optional).....	25
6.	Replacement procedures	27
7.	Disassembly and disposal	28
8.	Spare parts for SPEC HD cultivator	29

1. Introduction

We would like to congratulate you on the acquisition of the SPEC HD cultivator. This manual provides information on hazards that may occur when using and working with the cultivator, technical data and the most important indications and recommendations, the knowledge and application of which is a prerequisite for proper operation. Keep this manual for future use. If you do not understand any of the provisions of this manual, please contact the manufacturer.

Notes that are important for safety reasons are marked with the sign:



Machine identification

Identification data for the SPEC HD cultivator can be found on the rating plate on the main frame, which includes the CE mark, basic information about the manufacturer and the machine:



The guarantee for the cultivator is valid for 12 months from the date of sale.

The warranty card is an integral part of the machine.

Please always quote the serial number when making enquiries about spare parts.

Information on spare parts can be found:

- on the web site: <http://mandam.com.pl/parts/>
- phone +48 668 662 289
- E-mail: parts@mandam.com.pl

1.1. Safety signs and inscriptions







Remember! When using a cultivator, special care should be taken in areas marked with special information and warning signs (yellow stickers).

The signs and inscriptions on the machine are detailed below. Safety signs and inscriptions should be protected against loss and loss of legibility. *Signs and inscriptions that are lost and illegible should be replaced with new ones.*

Table 1 Information and warning signs

Safety signs	Meaning of the safety sign	Location on the machine
	Read the operating instructions before use.	Frame near mounting of the upper fastener.
	Crushing of the toes or foot.	Frame near mounting of the upper fastener.
	Keep clear of the lift bars while controlling the lift.	Frame near mounting of the upper fastener.

Safety signs	Meaning of the safety sign	Location on the machine
	<p>Keep a safe distance from foldable and moving parts of the machine</p>	<p>Front part of the mid frame near the side frames</p>
	<p>Do not reach into the crushing area if parts may move</p>	<p>Mid frame near side frames</p>
	<p>Pressurised liquid jet - bodily harm</p>	<p>Cylinders</p>
	<p>Fixing point for transport belts</p>	<p>Upper part of the drawbar (upper fastener bolt) Rear frame part:</p> <ul style="list-style-type: none"> • rigid frame (adjacent to the roller depth adjustment) • foldable frame (adjacent to the upper fastener bolt on the mid frame)

2. General information

2.1. Construction of the SPEC HD cultivator

The cultivators produced are available in working widths: 2.5m, 3.0m, 4.0m and 4.8m.

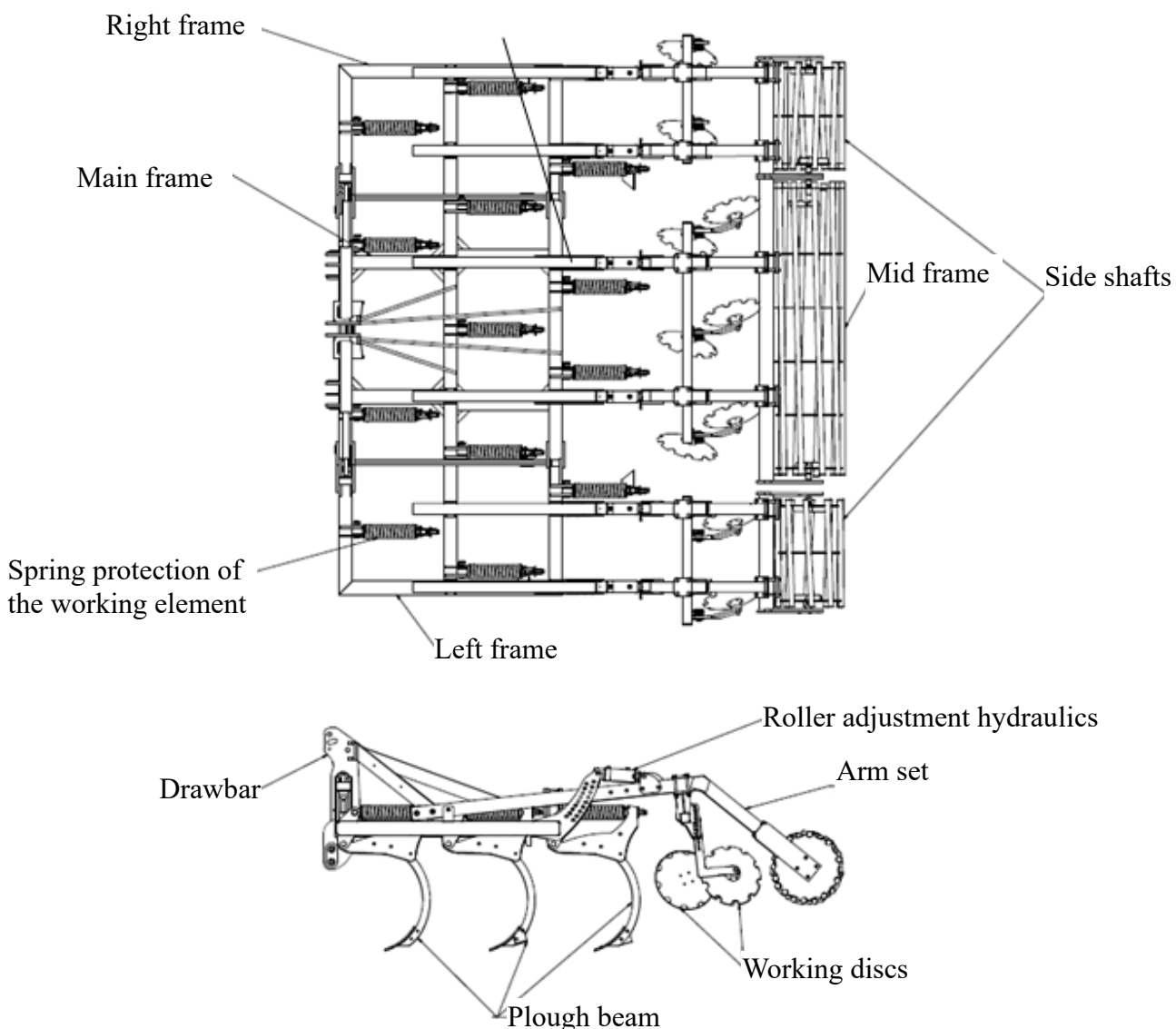

Fig.1 SPEC HD 4.0 H cultivator.

The main frame of the cultivator is the basic load-bearing element of the entire machine. In the version that exceeds a width of 3 m, the cultivator consists of a mid frame and side frames folded hydraulically into the transport position (Fig.1). The plough beams with working components are attached to the frame. Standard cultivators are equipped with a shaft and a disc beam mounted to the shaft arms. Each disc has its own bearing (maintenance-free hubs), allowing the disc to be optimally inclined to the direction of travel and the ground. The task of the discs is to level the soil surface distorted by the last row of working components. The shafts are used to compact opened soil and maintain the working depth of the cultivator.

Table 2 Types of the SPEC HD cultivator

Type	Working width [m]	Number of teeth [pcs.]	Number of discs [pcs.]	Min power res. [KM]	Weight [kg]
SPEC HD 2,5	2,50	8	7	110	1319
SPEC HD 3,0	3,00	10	8	130	1505
SPEC HD 4,0 H	4,00	13	10	180	2520
SPEC HD 4,8 H*	4,80	16	12	220	3365

**machine with integrated running gear*

2.2. Purpose of the SPEC HD cultivator

The SPEC HD cultivator is an all-purpose machine for shallow ploughing or used instead of ploughing for:

- shallow stubble cultivation (up to 15 cm) to mix post-harvest residues, stop soil water evaporation,
- increase the growth of weeds and self-seeding plants, and reduce ploughing resistance, or deep
- cultivation,
- deep cultivation (up to 35 cm) to loosen cultivated soil, mix mineral and organic fertilizers, and prevent
- mineralisation of humus in the ploughing soil.

The application of right and left side shields improves the degree of stubble mixing. As a result, the concentration of phenol compounds affecting the growth of crops in the following year is reduced. The application of the SPEC HD cultivator for deep cultivation eliminates the need of ploughing, and as such, this allows cost reduction, eliminates the risk of excessively compacted soil, and helps to complete farming work on time.



NOTE! The cultivator is designed exclusively for agricultural use. Use for any other purpose will be construed as misuse and will void the warranty. Failure to comply with the recommendations in these operating instructions will also be construed as misuse.



NOTE! The manufacturer is not liable for damage resulting from the operation of the machine not in accordance with its intended use.

3. General safety rules

The cultivator may only be used and repaired by persons who are familiar with its operation and the mating tractor and with the rules of conduct for the safe operation and handling of the cultivator. The manufacturer is not responsible for arbitrary changes to the design of the cultivator. During the warranty period, only factory-made "MANDAM" parts must be used.

The cultivator should be operated with all precautions in mind, in particular:

- before each start-up, check that the cultivator and the tractor are in safe condition when moving and working,
- use of the machine by minors, persons who are ill or under the influence of alcohol or other intoxicants is prohibited,
- use work clothes, footwear and gloves when carrying out maintenance work,
- permissible axle loads and transport dimensions must not be exceeded,
- use only original safety and split pins,
- when working with the cultivator, when lifting, lowering and unfolding, there should be no bystanders in the vicinity, especially children,

- it is forbidden to stay between the tractor and the cultivator while the engine is running,
- move forward, lift and lower the cultivator slowly and smoothly without sudden jerks, making sure that nobody stays in the vicinity,
- do not stand on the machine or put any additional weight on it during operation or transport,
- during u-turns, special care should be taken if there are bystanders in the vicinity,
- carry out any repairs, lubrication or cleaning of working parts only with the engine switched off and the machine lowered and unfolded,
- when not in use, the machine must be lowered to the ground and the tractor engine stopped, machines must be stored in such a way as to prevent injury to people and animals,
- It is forbidden to turn or reverse with the machine lowered.

3.1. Proper coupling and uncoupling of the machine to/from the tractor

- The attachment of the machine to the tractor must be made as specified, remembering to secure the pins and to secure the suspension pins with split pins.
- When coupling the tractor to the cultivator, it is forbidden for persons to stay between the machine and the tractor during this time.
- The tractor working with the cultivator must be fully operational. Coupling to a tractor with a defective hydraulic system is prohibited.
- Make sure that the tractor with the attached unit is stable, and the tractor steerability and stopping power can be maintained. The load on the front axle cannot drop below 20% of the total load on the tractor axle - set of front-mounted weights.
- In the resting position, the machine, when uncoupled from the tractor, should maintain a stable equilibrium.

3.2. Tyres

- Tyre pressures must not exceed those recommended by the manufacturer and it is forbidden to transport the machine at too low a pressure. This may damage the machine and cause an accident on large uneven surfaces and when driving too fast.
- Significantly damaged tyres (particularly profile damage) must be replaced immediately.
- When replacing tyres, the machine must be secured against rolling.
- Repair work on wheels or tyres should be carried out by persons trained and authorised for this purpose. This work should be carried out with appropriately selected tools.

Each time the wheels are fitted, the tightness of the nuts should be checked after 50km.

3.3. Hydraulic and pneumatic system

The hydraulic system is under high pressure. All precautions should be taken, in particular:

- do not connect or disconnect the hydraulic lines when the tractor's hydraulic system is under pressure (hydraulics set to neutral),
- regularly check the condition of the connections and the hydraulic and pneumatic hoses.
- the unit must be taken out of service while the hydraulic or pneumatic failure is being rectified.

3.4. Safety regarding transport on public roads

For transport, the side sections of the SPEC HD cultivator must be folded into the transport position using the hydraulic system. Before folding, the machine must be raised to the extent that the side sections do not interfere with the ground during folding.

During transport, the clearance under the machine should be at least 30 cm

While transporting the unit on public roads, it is mandatory to apply lighting equipment, identification

emblem and reflective side lights if the rear 3-point hitch is used.

The travelling speed during transport must not be exceeded:

- on roads with a smooth surface (asphalt) up to 20 km/h,
- on dirt or paved roads 6-10 km/h,
- on bumpy roads not more than 5 km/h.

The driving speed must be adapted to the condition of the road and the conditions on the road, so that the cultivator does not bounce on the tractor's suspension system and there are no excessive loads on the machine frame and the tractor's suspension system.

Particular care should be taken when passing and overtaking and on bends. The permissible width of the machine when travelling on public roads is 3.0 m. It is forbidden to transport the unit where the slope transverse to the aggregate exceeds 7°.



WARNING! Failure to comply with the above rules may create hazards for the operator and bystanders as well as damage to the machine. Damage resulting from non-compliance with these rules is the responsibility of the user.

3.5. Description of residual risk

Mandam Sp. z o.o. makes every effort to eliminate the risk of accidents. There is, however, a residual risk that could result in an unfortunate accident. The greatest danger occurs when:

- using the machine for purposes other than those described in the instructions,
- using the machine by minors, persons who are not authorised, who are ill or who are under influence of alcohol or other drugs,
- persons and animals within the operating range of the machine are present,
- no caution is paid when transporting and manoeuvring the tractor,
- staying on the machine or between the machine and the tractor while the engine is running,
- operating and failure to comply with operating instructions,
- driving on public roads.

3.6. Assessment of residual risk

Residual risk can be minimised by applying the following recommendations:

- prudent and unhurried operation of the machine,
- careful reading of operating instructions,
- keeping a safe distance from danger zones,
- prohibition on being on the machine and in the operating area of the machine while the tractor engine is running,
- carrying out maintenance work in accordance with safety rules,
- use of protective clothing and, if working under machinery, a helmet,

- prevention of unauthorised access to the machines, especially by children.

Hazards:

Noise: If the SPEC HD cultivator is used on stony soils, significant noise may result. In this case, it is advisable to keep the windows and doors of the tractor closed. You can also wear ear protectors.

Dust: In very dry conditions, very heavy dusting can occur. In such cases, it is recommended that the doors and windows of the tractor remain closed. In extreme conditions, a dust mask is recommended.

4. Information on handling and use

Before starting the machine for the first time:

- refer to the operating instructions,
- make sure the machine is in good working order,
- check the condition of the hydraulic system (replace components if damaged, e.g. pressure hoses),
- make sure that the machine's pressure hose couplings fit into the sockets on the tractor,
- check the tightness of the individual bolts and nuts,
- check the air pressure in the wheels in accordance with the manufacturer's recommendations,
- ensure that all components requiring lubrication are lubricated,
- ensure that the pressure in the tractor wheels is the same on each axle to ensure even operation.



NOTE! The permissible axle loads and tyre load capacities must not be exceeded. The front axle load must not be less than 20% of the total load. The tyre pressure should be in accordance with the manufacturer's recommendations

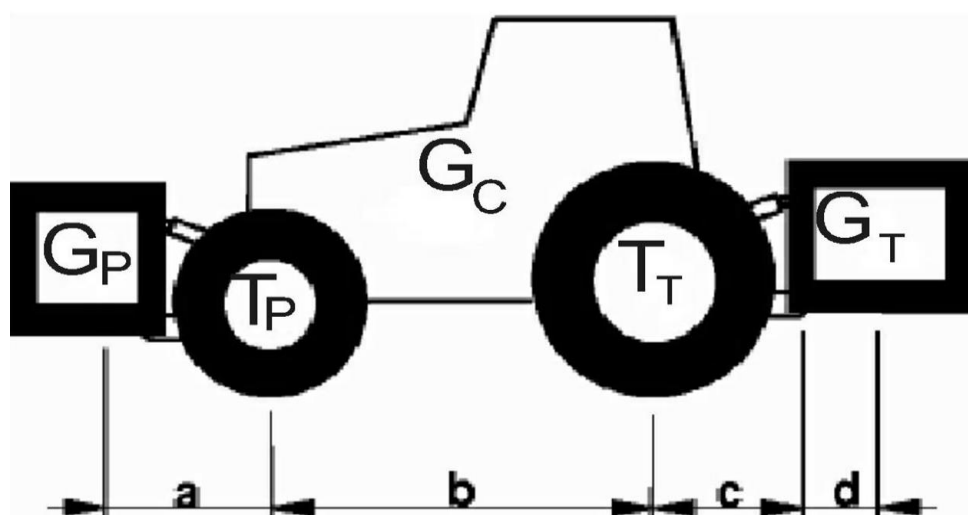

Fig. 2 Diagram of tractor load designations.

Axle load calculations

Designations:

G_C - tractor weight,

T_P - front axle load of the empty tractor,

T_T - rear axle load of the empty tractor,

G_P - total weight of front-mounted device,

G_T - total weight of rear-mounted device,

a - distance between the centre of gravity of the front-mounted device and the centre of the axle,

b - tractor wheel track,

c - distance between the centre of the rear axle and the centre of the hitch bolt of the rear device,

d - distance of the machine's centre of gravity from the tractor's hitch bolt (for all widths assume 1.9 m)

x - distance of the centre of gravity from the rear axle (if the manufacturer does not specify this parameter, enter 0.45).

Minimum load at the front for rear-mounted machine:

$$G_{Pmin} = \frac{G_T \cdot (c + d) - T_P \cdot b + 0,2 \cdot G_C \cdot b}{a + b}$$

Minimum load at the back for front-mounted machines:

$$G_{Tmin} = \frac{G_P \cdot a - T_T \cdot b + x \cdot G_C \cdot b}{b + c + d}$$

Actual front axle load:

$$T_{Pcal} = \frac{G_P \cdot (a + b) + T_P \cdot b - G_T \cdot (c + d)}{b}$$

Actual total weight:

$$G_{cal} = G_P + G_C + G_T$$

Actual rear axle load:

$$T_{Tcal} = G_{cal} - T_{Pcal}$$

4.1. Preparing the cultivator for work

The cultivator is usually delivered ready for work. Due to the limitations of transport facilities, it is also possible to deliver it in a partially dismantled state - this usually involves disconnecting the rear shaft, disc beam and discs.

When the unit is first prepared for use, its components must be assembled: cultivator, shaft and discs. To do this, place the cultivator on a flat hard surface in a position that allows the shaft to manoeuvre. Position the shaft arms in the cultivator brackets and connect the arms to the shaft bracket with screws (Fig. 3). Then mount the beam with discs to the shaft arms. The discs should be set so that their work causes the furrows created by the coulters of the last row of the cultivator to be filled in. There is one pair of discs per plough beam in the last row (left and right discs - Fig. 4).

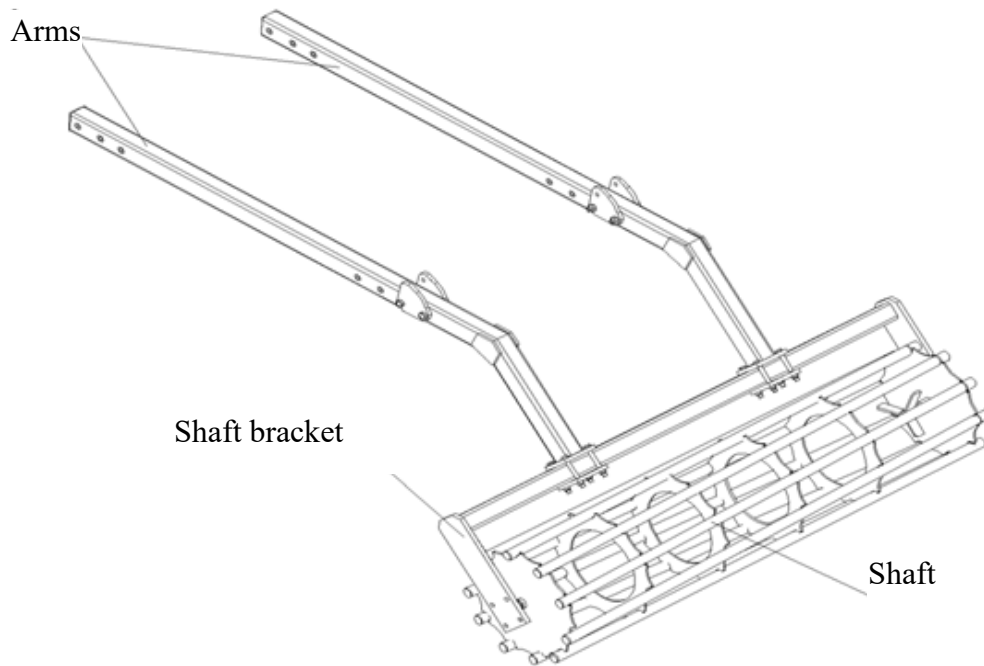

Fig. 3 Connection of the arms with shaft bracket.



NOTE! The correct procedure for mounting the shafts in the arm holders requires that the bolts be evenly tightened diagonally, so that the entire plane of the arm holders is adjacent to the plane of the shaft clamp profile. This provides the most secure way of connecting the shaft arms to the machine!

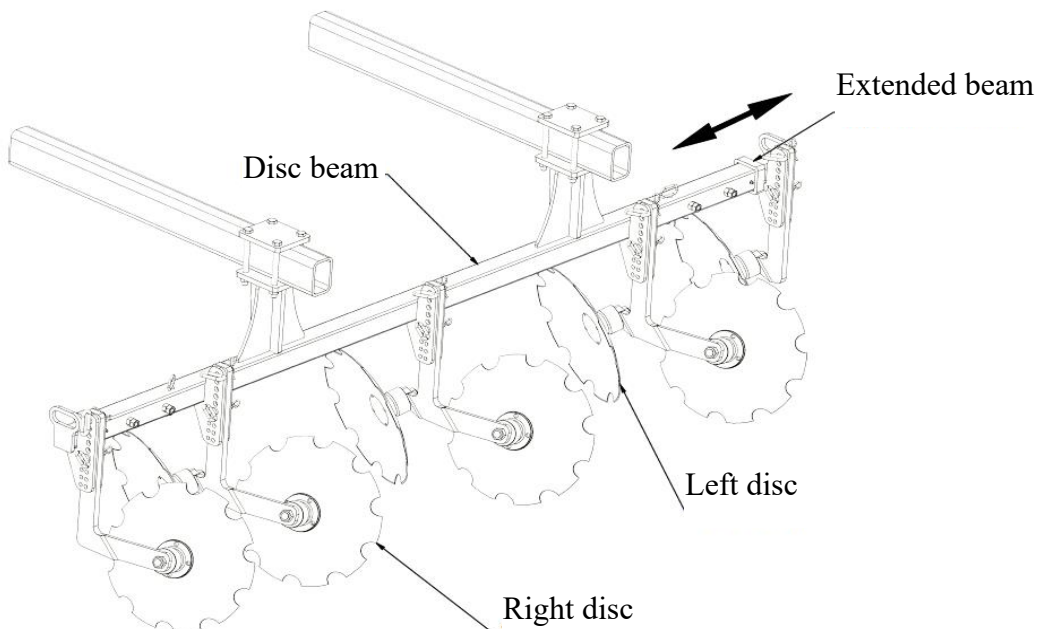

Fig. 4 Arrangement of discs on the beam.



NOTE! While preparing the machine for deep soil cultivation, dismantle all cutting wings as they may contribute to extensive compaction of the soil, resulting in plough pan effect, and increase the operating resistance.

SPEC HD cultivators are optionally available with a disc beam with disc holders with rubber protection to prevent the holders from twisting excessively during machine operation (Fig. 5).

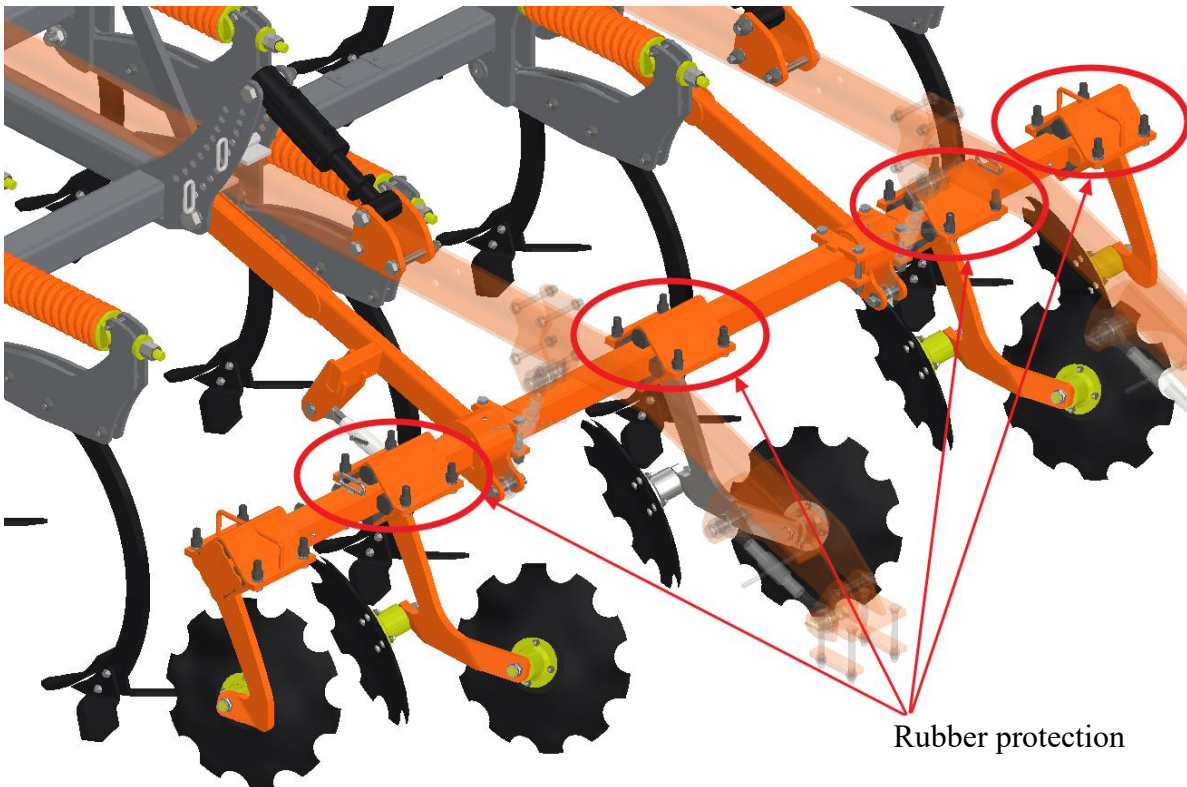

Fig. 5 Disc beam with rubber protection.

4.2. Coupling the cultivator to the tractor

The tractor wheel tyre pressure should be in accordance with the manufacturer's recommendations. The lower links of the three-point hitch should be at an equal height, at a spacing corresponding to the spacing of the lower suspension points. When connecting the cultivator to the tractor, the cultivator should stand on firm and level ground.

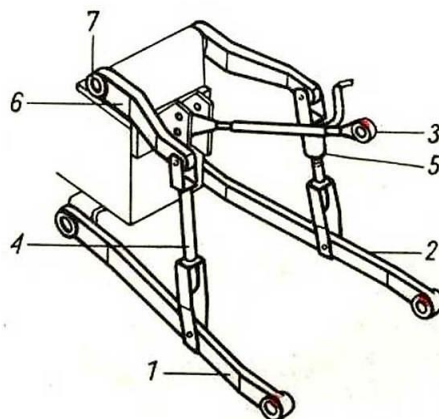

Fig. 6 Three-point suspension system of the tractor's three-point hitch: 1,2 - lower links, 3 - upper fastener, 4 - left suspension, 5 - right suspension with adjustable length, 6 - lift arm, 7 - lift shaft

When attaching the cultivator to the tractor's three-point hitch, perform the following steps:

- switch the tractor's hydraulic system to position control,
- remove the lower hitch bolts (in case the tractor linkage is not equipped with hooks),
- drive up carefully, suspend the machine from the lower links, then secure,
- connect the top upper fastener on the tractor. During operation of the unit, the hitch point of the upper fastener at the unit must be higher than the attachment point of this fastener at the tractor,
- check the lifting and lowering of the cultivator and the operation of the hydraulic system.

Any tractor that is used with the machine must be equipped with a set of weights and must remain steerable during transport, i.e. a minimum of 20% of the tractor's weight must be on the front axle.



NOTE! Hitching the tractor to the cultivator must be done carefully, at minimum tractor speed! When hitching the machine, make sure there are no bystanders in the vicinity.

4.3. Operation and adjustment

4.3.1. Side arms adjustment

On cultivators with folding side frames, the level adjustment of these frames must be carried out using the screws built into the front and rear of the mid frame (at each hinge - Table 3). Properly adjusted side arms should be at the same level as the mid frame. Once adjusted, secure the screw with a lock nut.

Table 3 Side frame level adjustment.

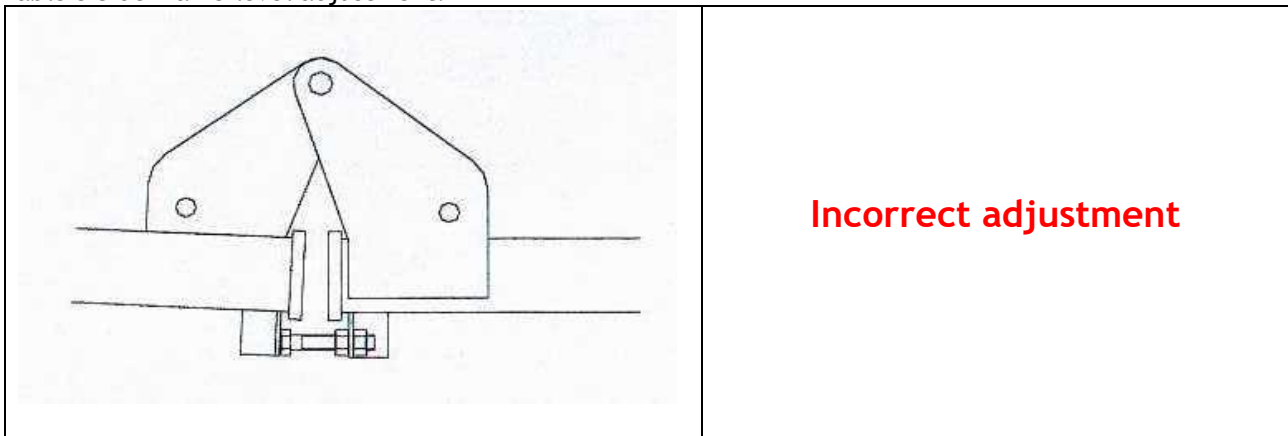

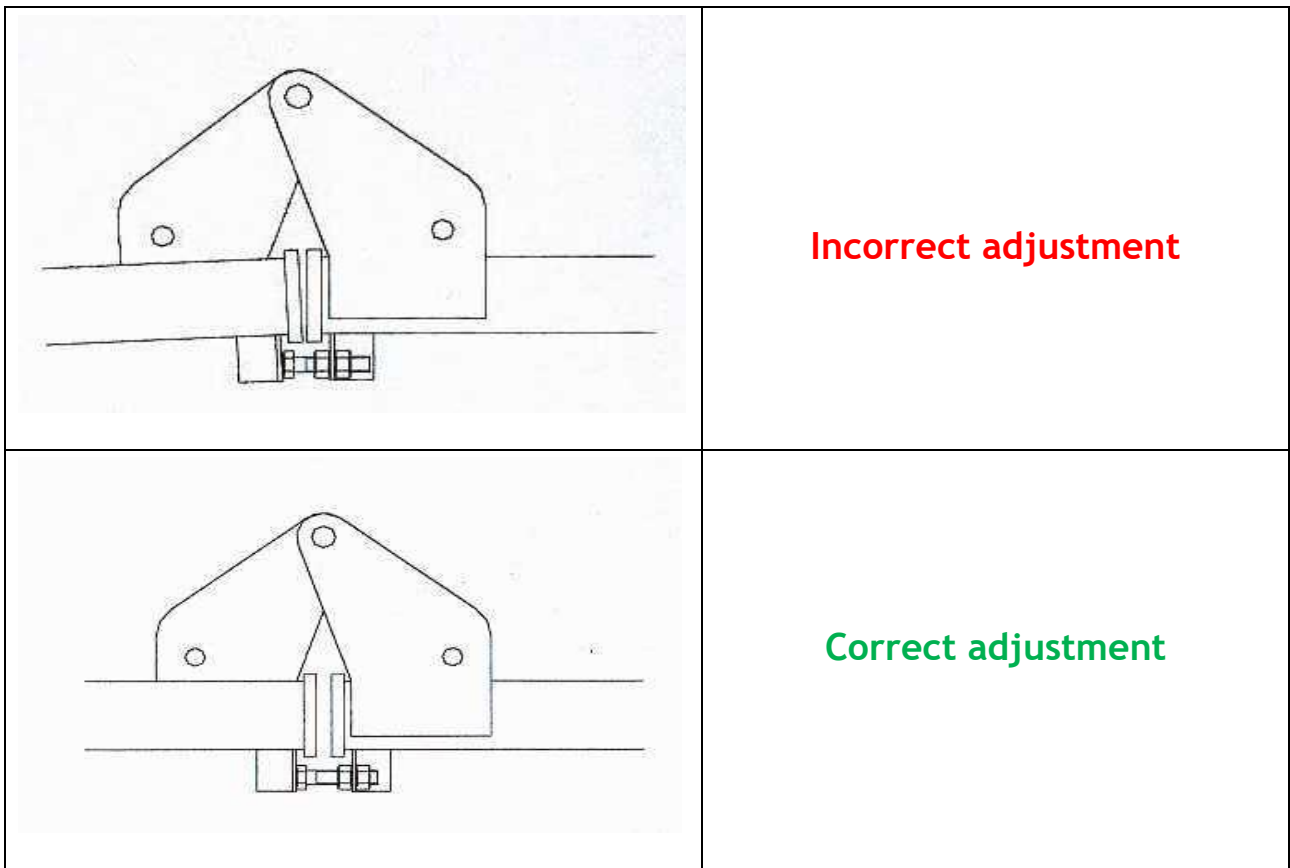

Before carrying out field work with an unit with folding side arms, the hinge lock **must** always be in place and secured with a cotter pin (Fig. 7).

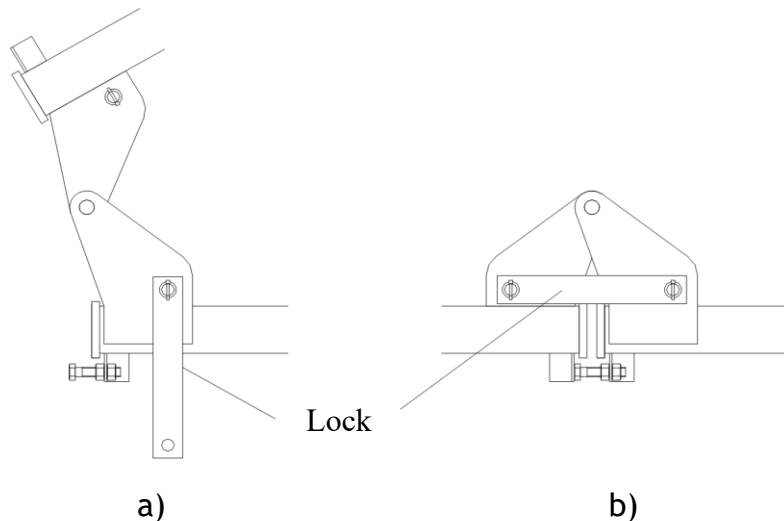

Fig. 7 Lock in transport position (fig. a), lock in working position (fig. b).



NOTE! It is forbidden to carry out field work with units with folding side arms without the hinge lock in place.

Remember to remove the hinge lock before lifting the side arms into the transport position.

A properly hitched cultivator should follow the tractor evenly during operation and loosen the soil uniformly over the entire working width. For longitudinal levelling, use the

tractor's top link (turnbuckle), while for transverse levelling, use the crank on the tractor's right-hand suspension.

4.3.2. Working depth adjustment

The working depth is adjusted by changing the height of the roller in relation to the cultivator frame using the tractor's hydraulic lift and pins with stabilising plates inserted into pre-drilled plates fixed on the frame (Fig. 8). It is also possible to change the distance of the shaft from the cultivator frame (screw in Fig. 8). Note that too little distance between the tines and the plates can cause clogging with plant residues.

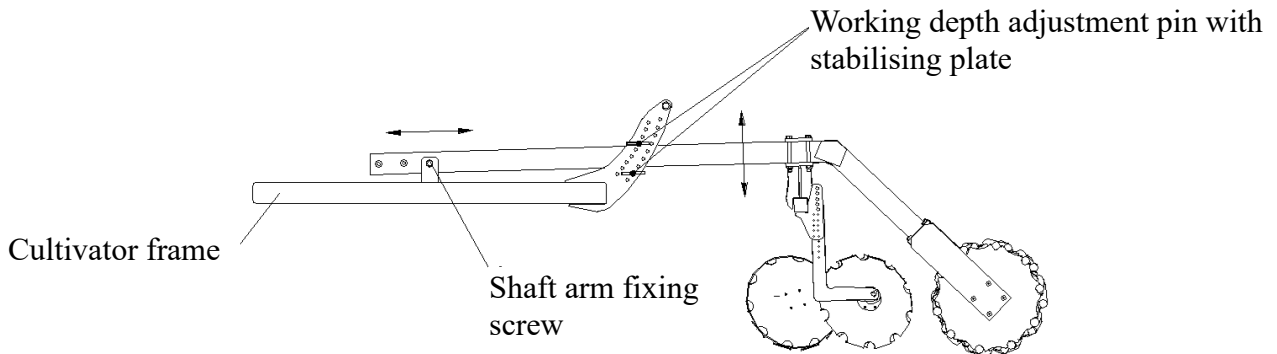

Fig. 8 Adjusting the depth and distance of the tubular shaft.

An optional version of the cultivator with mechanical adjustment of the working depth using turnbuckles (fig. 9) and a version with hydraulic adjustment of the working depth (fig. 10) are available. In this case, the arms of the working shaft are adjusted by hydraulic cylinders.

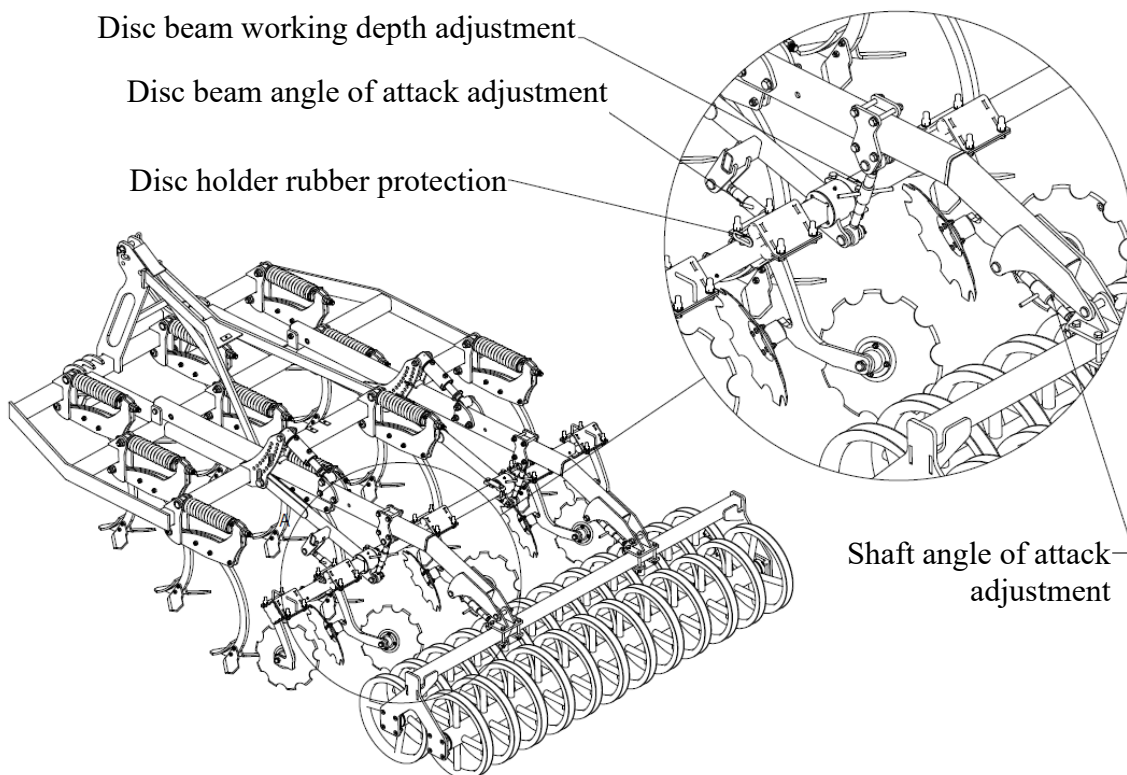

Fig. 9 Mechanical adjustment of tube shaft depth using turnbuckles.

The working depth of the machine is set in this case by means of turnbuckles, which adjust the suspension distance of the disc beam in relation to the shaft arms. As this distance increases, the working depth of the discs increases. When changing the aforementioned distance between the disc beam and the working shaft arms, the angle of attack of the disc beam must be adjusted with the horizontal turnbuckle so that the discs are always oriented horizontally relative to the field plane. The same procedure should be carried out with respect to the working shafts, also changing their angle of attack if the height of the shaft arm suspension changes.



NOTE! When changing the depth of the discs using a turnbuckle, remember that the discs should always be below the level of the working shaft in order for them to work properly!

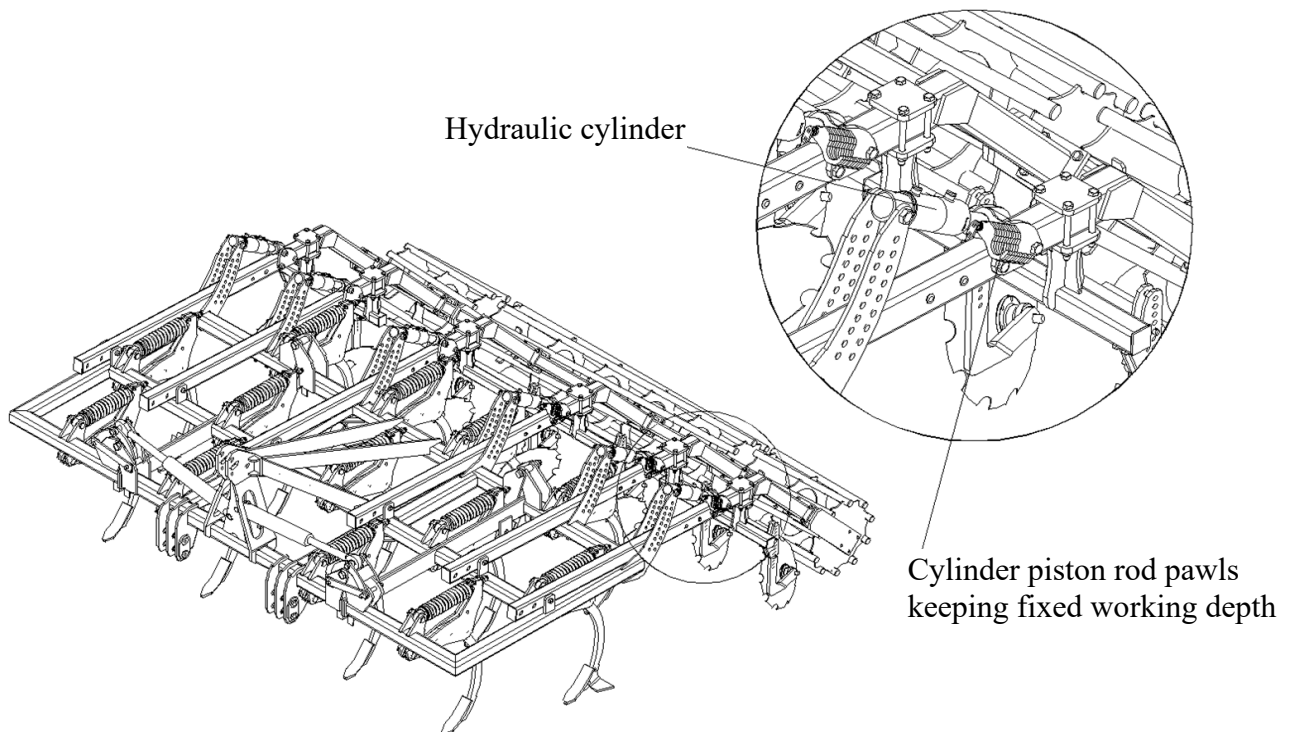

Fig. 10 Hydraulic depth adjustment of the tube shaft.

For machines with hydraulic adjustment of working depth, the working depth of the machine is set using pawls located at the piston rod of the cylinder. As more pawls are folded, the operation of the machine becomes shallower. In a configuration where none of the pawls are installed, the machine is in its greatest working depth configuration. In (Fig. 11 and Fig. 12), the correct way of installing the subsequent pawl plates on the actuator and the incorrect way of installing them are shown.

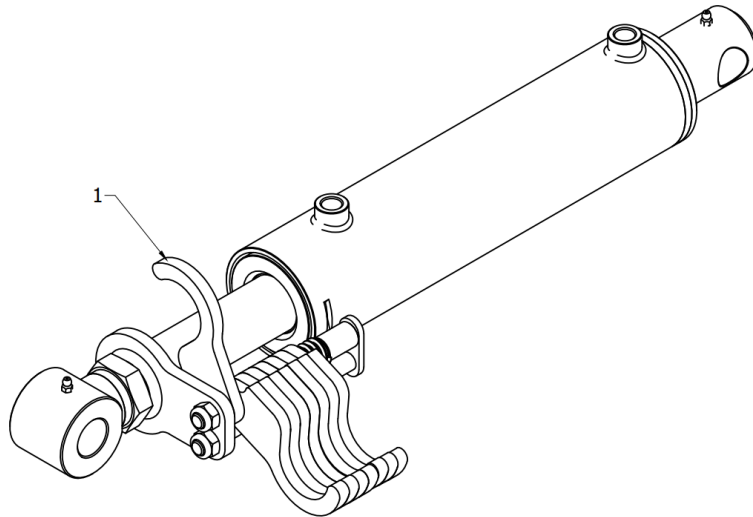

Fig. 11 Correct way to put the first (1) pawl on the piston rod of the cylinder to adjust the working depth of the machine.

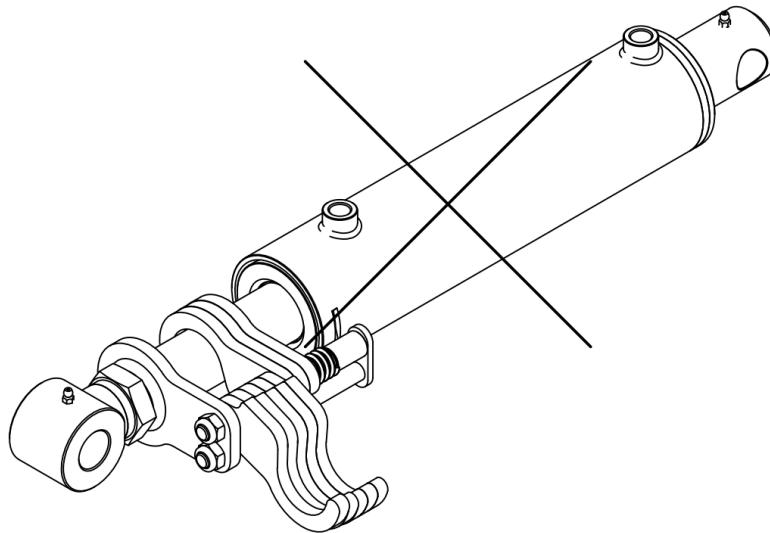

Fig. 12 Incorrect installation of pawls on cylinder piston rod. Partial omission of the attachment of the pawls to the cylinder results in uneven distribution of the forces acting on the piston rod and can lead to piston rod buckling resulting in damage to the entire cylinder assembly. This kind of adjustment is **unacceptable!**

The number of pawls on all shaft arm cylinders must always be equal!

The working depth of the discs is set according to the depth of the cultivator. The discs must work on the surface to evenly level the soil behind the plough beams.

The SPEC HD cultivator elements can be adjusted in terms of angle of attack. The more horizontal position of the coulters reduces working resistance and undercuts the stubble with low loosening - recommended for compact soils with optimum moisture content and soils of medium and low compactness (nut on the spring screw). The steeper position of the coulters facilitates penetration and loosens the soil to a greater extent - recommended for hard and dry soils. Note that as the screw twist changes, so does the strength of the protection induction.



WARNING! It is forbidden to make adjustments to the machine while the tractor engine is running.

The working speed of the SPEC HD cultivator under normal operating conditions should be 8 - 12 km/h.

The machine must be raised before turning and during reverse travel.

4.4. Rules for transporting the cultivator on public roads and lighting the machine

In accordance with the road safety regulations (Regulation of the Minister of Infrastructure of 31.12.2002. Journal of Laws No. 32 of 2002, item 262) - the unit consisting of the agricultural tractor and the agricultural machine coupled with it must meet requirements identical to those imposed on the tractor itself.



NOTE! The unit as a part of the vehicle protruding beyond the rear side contour of the tractor obscuring the rear lights of the tractor poses a danger to other vehicles on the road. Remember to follow the transport recommendations in the chapter: 3 "General safety rules". It is forbidden to travel on public roads without appropriate markings.

The units should be equipped with:

- triangular plate to distinguish slow-moving vehicles,
- two forward-facing plates having a white position light and a white retro-reflector,
- two rear-facing plates having a combination light and a red reflector. The plates should be painted with diagonal white and red stripes.

Once the plates have been fixed, the electrical wires of the warning-light device should be connected to the socket of the tractor's electrical installation.

The manufacturer does not supply warning signs as standard equipment on the machine. Warning signs are available commercially.

Driving style should always be adapted to the road conditions - this will help avoid accidents and damage to the chassis. Consider your own skills and the intensity of the movement, the prevailing visibility and the weather.

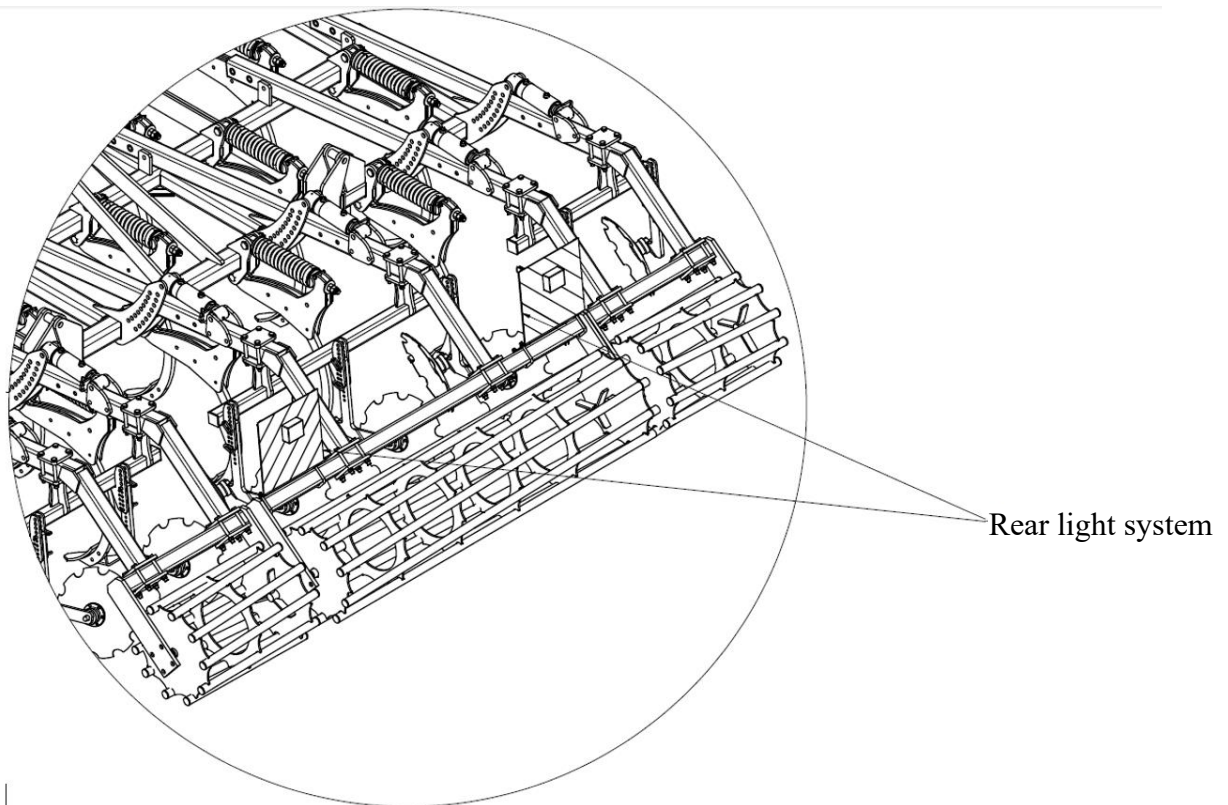

Fig. 13 Lighting and rear light assemblies and their location.

Before transporting, the machine should be cleaned from the soil and the operation of the lights checked. After lifting the machine, check the clearance under the lowest working elements, which should be at least 25 cm. The permissible transport speed of the tractor with the machine is 15 km/h. It should be reduced to 10 km/h on roads with poorer surfaces and 5 km/h on dirt roads. Extreme caution should be exercised when passing and overtaking other vehicles, avoiding obstacles and crossing large irregularities in fields and dirt roads.

4.5. Maintenance and lubrication

- Each time the cultivator is finished working, the soil must be cleaned, followed by an inspection of the parts and assemblies. **Otherwise, there may be a problem with the folding of the machine if the shafts are clogged with soil and there is an additional load!**
- Re-tighten all screws after the first 4 hours of operation and periodically check the tightness. **Failure to do so will exacerbate backlash and result in damage to the machine.**
- The blade tips can be used almost until they are worn down, until the working surface is equal to the initial blade foot surface. However, it is advisable to replace the tips early enough before there is a possibility of wear and damage to the blade foot.
- Lubricate the grease points on the hinge pins daily during the life of the machine. Lubricate the bearings of the shaft and the levelling discs every 25 operating hours (does not apply to maintenance-free disc bearings - these bearings do not need to be serviced and lubricated).
- When replacing worn components, use thread glue, original bolts and nuts.
- For screwing the working elements, use M12 screws, class 10.9 and tighten them with a torque of 135Nm.

- Damaged or worn parts must be replaced with new or reconditioned parts.
- Always ensure that screw connections are properly tightened.

NOTE! Periodic lubrication is a guarantee of the durability of the machine.

The service life and efficiency of the machine depend to a large extent on regular lubrication. Mineral lubricants should be used for lubrication. Lubrication points must be thoroughly cleaned before pressing in or applying grease.



NOTE! It is forbidden to work on a damaged machine caused by any event resulting in a broken, or deformed frame, shaft or other assembly of the machine!

4.6. Screw tightening torque

Bolts and nuts should be tightened in the machine with the correct torque depending on the strength class of the bolt and its thread size and pitch. Their respective tightening torque values are shown in Table 4.

Table 4 Tightening torque values for nuts and bolts.

Tightening torque for nuts and bolts [Nm]					
		Thread pitch	Bolt strength class		
			8.8	10.9	12.9
Dimensions	M4	0,7	3,2	4,5	5,2
	M5	0,8	6	8,4	10
	M6	1,0	11	15	17
	M8	1,3	27	34	40
		1,0	21	30	35
	M10	1,5	46	65	76
		1,3	41	75	67
		1,0	36	50	59
	M12	1,8	79	111	129
		1,3	65	91	107
	M14	2,0	124	174	203
		1,5	104	143	167
	M16	2,0	170	237	277
		1,5	139	196	228
	M18	2,0	258	363	422
		1,5	180	254	296
	M20	2,5	332	469	546
		1,5	229	322	375
	M22	2,5	415	584	682
		1,5	282	397	463
	M24	3,0	576	809	942
		2,0	430	603	706
	M27	3,0	740	1050	1250
		2,0	552	783	933
M30	3,5	1000	1450	1700	
	2,0	745	1080	1270	
M36	4,0	1290	1790	2020	
	2,0	960	1340	1500	



NOTE! It is forbidden to work on a damaged machine caused by any event resulting in a broken, or deformed frame, shaft or other assembly of the machine!

5. Everyday service

Each time the cultivator is finished working, it should be cleaned of soil, plant residues and the condition of the screws and pin connections and the condition of the working elements and other parts should be inspected. During cleaning, plant debris and strings winding up on the bearing points of the shaft should be removed. If parts are found to be damaged or worn, they should be replaced. All loose screw connections must be tightened and damaged cotter pins and pins must be replaced.

5.1. Out-of-season handling and storage

At the end of the working season, the cultivator should be thoroughly cleaned and any damage to the paintwork repaired. The stripped working surfaces of the teeth, discs, strings and shaft rings, as well as the threads of the adjusting screws, must be washed, dried and preserved. In addition, full lubrication should be carried out. It is advisable to store the machine under a canopy when not in use. If this is not possible, the condition of the protection should be checked from time to time and rain-washed grease should be replenished if necessary. **The cultivator should be stored in a place that poses no danger to persons or the environment.** The machine, when uncoupled from the tractor, should be supported on firm and level ground. Also, components dismantled from the machine should be stored securely supported on the ground, excluding possible uncontrolled movement.

Clean the piston rods of the hydraulic cylinders during winter and when the machine is not in use for a long period of time, and protect them with vaseline or acid-free grease to protect them from corrosion.

5.1.1. Operation of the hydraulic system

Maintenance of the hydraulic system (Figure 14) consists of a visual inspection for leaks. Remember to put plugs on the quick-release couplings. If there is any oil leakage at the connections of the hydraulic lines, the coupling must be tightened. If this does not rectify the fault, the component or hose must be replaced with a new one. Leakage occurring outside the connector - the leaking hose must be replaced with a new one. Mechanical damage also requires replacement of the component. It is recommended to replace the hydraulic hoses every 5 years. If there is oil on the piston rod of the hydraulic cylinder, the nature of the leak should be checked. When the piston rod is fully extended, check the sealing points. Minor leaks characterised by wetting of the piston rod (so-called oil film) are acceptable. In the event of stronger "sweating" or the appearance of droplets, the unit should be switched off for the duration of the fault rectification (defective unit ring).

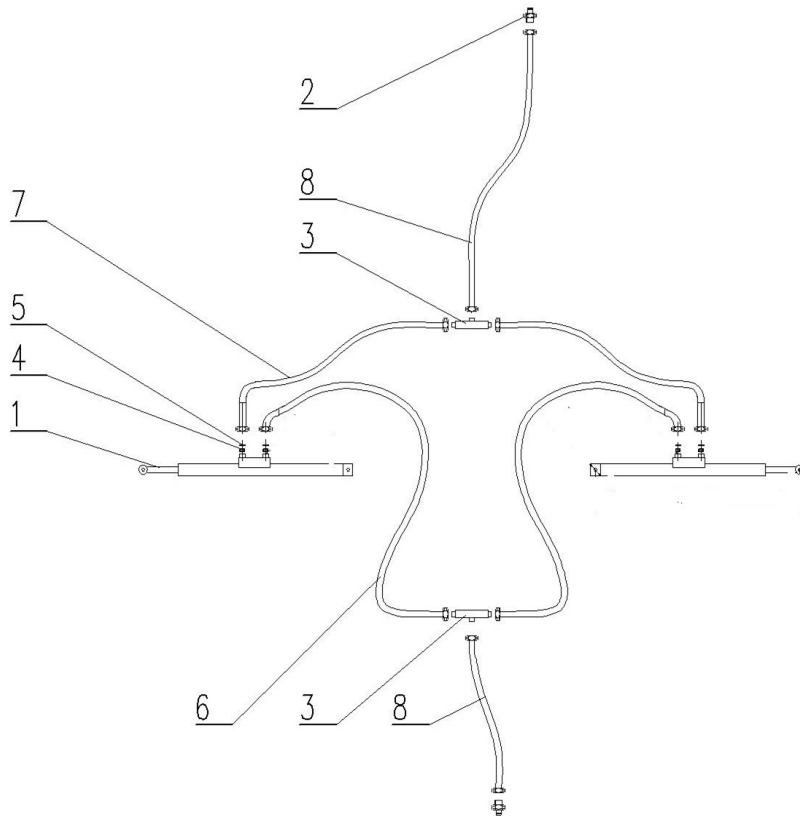

Figure 14 Diagram of the SPEC HD hydraulic system: 1- cylinder, 2- quick coupling, 3- tee, 4- orifice, 5- copper washer, 6- hydraulic hose 1m, 7- hydraulic hose 0.7m, 8- hydraulic hose 2.2m.

5.1.2. SPEC HD running system handling (optional)

As an option, the SPEC HD cultivator can be equipped with a transport trolley (fig. 15). This trolley can also have its own brake axle (pneumatic system).

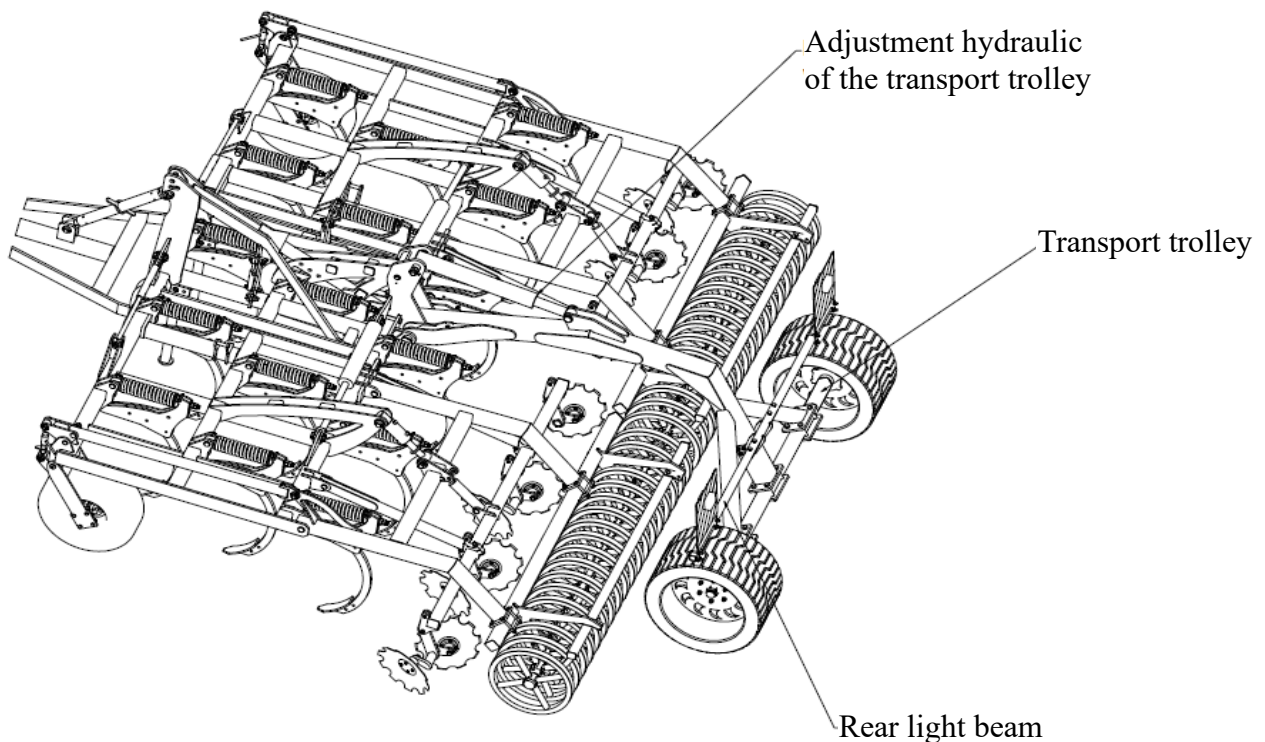

Fig. 15 SPEC HD cultivator equipped with a transport trolley (optional).

Regular control of wheel pressure. If there is a significant loss of air from the tyres, check the air valve for leaks. Next, take the wheel to a specialised workshop to locate and repair the damage. Significantly damaged tyres (particularly profile damage) must be replaced immediately.

Setting of wheel bearing axial clearance.

It is recommended that this operation is carried out by a specialised company. Performed by tightening the nut on the wheel hub after the wheels have been removed. The recommended clearance is 0.12-0.15 mm. Inspection and adjustment should take place every 2 years.

Procedure :

- Removal of the hub cover and the spring pin securing the spring nut.
- At the same time, while turning the hub, press down and tighten the crown nut.
- Tightening is complete when no more than half a turn of the hub is caused by vigorous hand rotation.
- Partially loosen the nut until the hub rotates freely and repeat the tightening.
- After repeated rotation locking, loosen the nut by 30° max. until the immediate nut locking with the pin is possible. Mark the position with a line.
- From the marked position, unscrew the nut by half a turn and, with a gentle tap, press the hub against the nut as far as it will go.
- Tighten the nut to the position marked with the line.
- Fit the hub cover.

NOTE! During maintenance work, the unit should be secured against rolling (it should be connected to the tractor with the parking brake on) and unfolded.



Operation of the brake system (pneumatic system)

The three-range brake force regulator is not adjustable under normal use. It should be in a central position. If the braking force deviates from that of the tractor, the regulator can be adjusted to avoid incorrect road behaviour. When making any change, be sure not to cause an accident or damage to the machine.

The removal of condensed water in the tank is carried out by means of a valve located underneath the tank. The stem must be pressed, which will cause the compressed air to displace the water. Releasing the stem will automatically close the valve. Once a year (before winter) the drainage valve should be unscrewed and cleaned.

Checking the pneumatic system involves visually inspecting for leaks, especially at the connection points (when checking the system, the pressure should not be less than 6 atmospheres). If hoses, seals and other system components are damaged, this will manifest itself as hissing. Bubbles will appear at small leaks (check by applying wash liquid). **Damaged components should be replaced with new ones.**

Braking adjustment - braking deceleration levelling, should be carried out when:

- As the lining jaws wear during use and as a result of the resulting clearance, the braking force decreases,
- the wheel brakes brake unevenly and inconsistently.

To do this, the position of the spreader arm on which the piston rod of the pneumatic cylinder acts must be changed. Change the starting angle of the spreader shaft on the multi-shaft end and correct the length of the linkage on the bolt. Adjustments should be carried out for each wheel separately.

6. Replacement procedures

Bearing replacement.

If the bearings are damaged, they must be replaced:

- place the machine on a horizontal surface,
- unscrew the four screws holding the ball bearings on each side,
- move the tubular shaft away,
- loosen the two headless screws on each bearing and pull off the bearings using an extractor,
- fit the new bearings loosely onto the shaft,
- roll the shaft between the bearing plates and screw the bearings to them. Screw in headless screws using adhesive to prevent loosening.

Replacement of working components

Excessively worn working components make it difficult for the tools to sink in, increase working resistance and insufficiently mix harvest residues. The working components must be changed on the machine lowered to the ground after the tractor engine has been switched off. To ensure that the components to be replaced do not rest on the ground, sturdy shims should be placed under the shaft. After lowering the cultivator, switching off the engine and applying the handbrake, check the stability of the tractor-machine unit. Only typical screws should be used to fix new components.

If machine components are disassembled several times, it is necessary to inspect and possibly replace connecting elements such as bolts, washers or nuts, excessive wear of which may lead to uncontrolled loosening of the connecting elements and subsequent damage.

When working on extremely worn work tools, such work can cause, for example, bearing damage in the case of a small disc diameter. Tools should be replaced when their wear and tear exceeds the limits allowed by the manual. If the recommendations are not followed, damage may occur for which the manufacturer is **NOT RESPONSIBLE!**

Replacement of cylinders

A malfunctioning cylinder, leakage, etc. should be dismantled and taken to a specialist workshop. Replacement of the cylinder must be carried out on an unfolded machine. Connect the cylinder to the system and, when mounted on one side, run through the entire cycle a couple of times to fill the cylinder completely with oil. Failure to do so may result in a sudden fall of the drop section.

The bearings of the levelling discs are not demountable. If damaged, they should be replaced in their entirety.



NOTE! When carrying out repairs and maintenance, the machine should be lowered to the ground and supported on supports to ensure full stability and the tractor engine switched off. Use proper spanners and protective gloves during maintenance and repairs.

7. Disassembly and disposal

A machine used in accordance with the instructions in this manual will last for many years, but worn or damaged parts must be replaced. In the event of emergency damage (cracks or deformation of the frames) impairing the quality of the machine and posing a danger to further operation, the machine must be disposed of.

The disassembly of the machine should be carried out by persons previously gotten familiar with its construction. These operations should be carried out after the machine has been set up on a level and stable surface. Sequence of activities:

- Disconnect the shaft bracket from the arms. Remove the bearing mounting bolts and roll the shaft to one side.
- Disconnect the shaft arms from the frame.
- Remove the three-point hitch turret arms connecting to the main frame (for non-welded three-point hitch).
- Remove the three-point hitch turret.
- Place the frame on stable stands. For units with folding side arms, additional stands must be prepared.
- Remove the working components of the unit.
- Detach the side arm supports from the mid frame.
- Disassembly of hydraulic components should be carried out wearing gloves and protective goggles. Wrap the connectors with oil cloth before unscrewing the bent wires. Drain the used oil into a container (bucket).



Store the machine securely supported on a hard surface to prevent injury to people or animals.



NOTE Take all precautions when dismantling the machine by using operable tools and personal protective equipment. Disassembled parts must be disposed of in accordance with environmental protection requirements.

8. Spare parts for SPEC HD cultivator

To search, price and order genuine spare parts for MANDAM machines, please visit our website at: www.mandam.com.pl, tab "Parts". On this page, we provide catalogues and spare parts sheets in PDF format, containing up-to-date parts diagrams for each machine, together with their numbers and prices.

Parts orders, or enquiries regarding them, can be made directly from this page (tab: "contact/order") or via e-mail: [*parts@mandam.com.pl*](mailto:parts@mandam.com.pl)
The order should include the part numbers and quantities, as well as the purchaser/payer's details including a contact telephone number.

Parts are shipped directly to the address provided and payment is made on delivery. If you are not sure, please contact the Mandam spare parts department on the following telephone numbers : +48 32-232-2660 ext. 39 or 45 or on the mobile number +48 668-66-22-89.

Original MANDAM spare parts are also available from all authorised MANDAM machine distributors.