

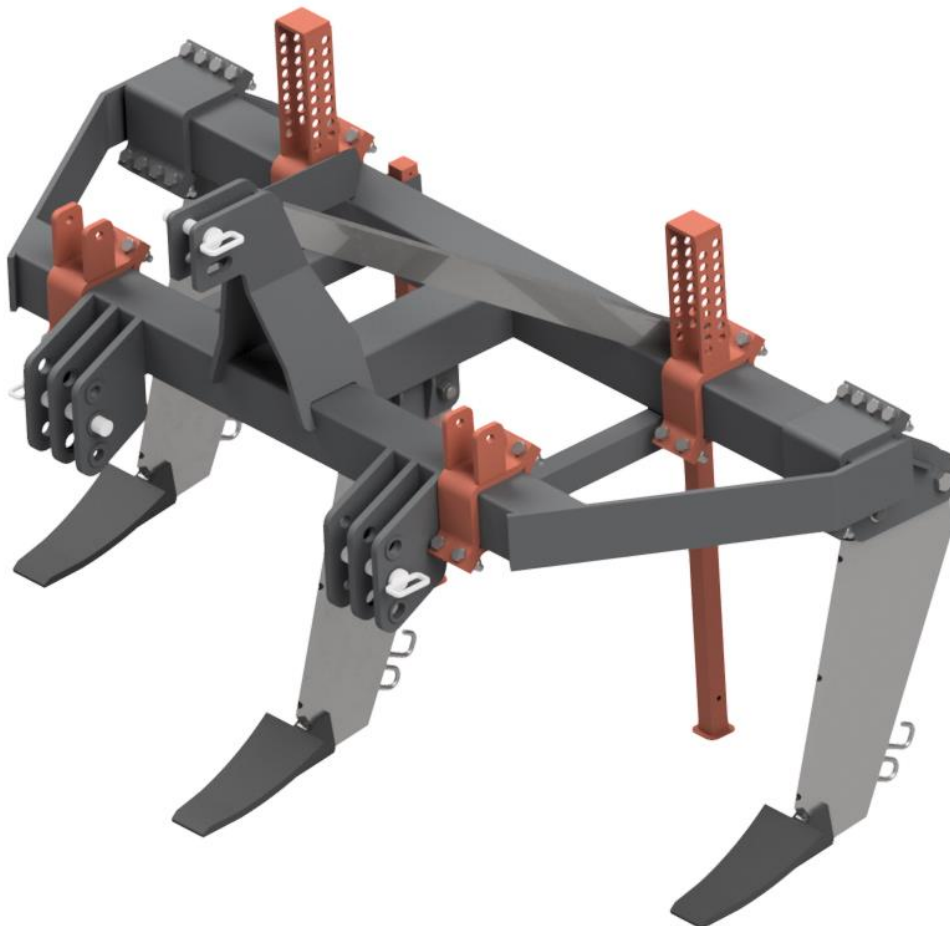

MANDAM Sp. z o.o.
44-100 Gliwice ul. Toruńska 14
e-mail mandam@mandam.com.pl
Tel.: 032 232 26 60 Fax: 032 232 58 85
NIP No.: 648 000 16 74 REGON No.: P - 008173131

OPERATING MANUAL

MGX SUBSOILER



Edition I
Gliwice 2023



DECLARATION OF CONFORMITY EC



FOR THE MACHINE

Pursuant to the Regulation of the Minister of Economy of 21 October 2008 (Journal of Laws No. 199, item 1228) and the EU Directive No. 2006/42/EC of 17 May 2006,

MANDAM Sp. z o. o.

ul. Toruńska 14

44-100 Gliwice

declares with full responsibility that the machine:

MGX SUBSOILER

type/model:

year of production:

serial No.:

to which this declaration shall apply meets the requirements of:

Regulation of the MoE of 21 October 2008 on the essential requirements for machines (Journal of Laws No. 199, item 1228)

and the EU **Directive** No. 2006/42/EC of 17 May 2006.

Persons responsible for the technical documentation of the machine: Jarosław Kudlek, Łukasz Jakus

ul. Toruńska 14, 44-100 Gliwice

The following standards were also used to assess compliance:

PN-EN ISO 13857:2010,

PN-EN ISO 4254-1:2016-02,

PN-EN ISO 12100-1:2005/A1:2012

PN-EN ISO 12100-2:2005/A1:2012

PN-EN 982+A1:2008

This EC declaration of conformity expires,
if the machine is modified or converted without the approval of the manufacturer.

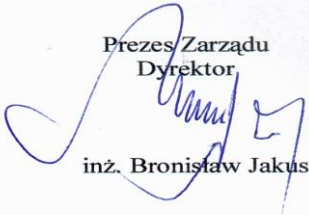
Prezes Zarządu
Dyrektor

inż. Bronisław Jakus

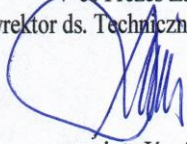
President of the Management
Board Director

Vice Prezes Zarządu
Dyrektor ds. Techniczno-Organizacyjnych

mgr inż. Józef Seidel

Vice President of the Management Board
Technical and Organizational Director

.....
Place and date of issue

.....
*Last name, first name, position
and signature of the authorized person*

Table of contents

1	Introduction	4
1.1	Safety signs	5
1.2	Design of the MGX subsoiler	7
2	Intended use	7
3	General safety rules	8
3.1	Coupling and uncoupling from the tractor	9
3.2	Tires	9
3.3	Safety related to transport on public roads	9
3.4	Description of the residual risk	10
3.5	Assessment of the residual risk	10
4	Handling and Usage Information	11
4.1	Handling and Usage Information	13
4.2	Coupling the subsoiler with the tractor	14
4.3.	Maintenance and lubrication	15
4.4.	Screw tightening torque	15
5	Service	16
5.1	Daily service	17
5.2	Off-season service	17
5.3	Servicing the support wheel assembly	17
6	Replacement procedures	17
7	Storage of the subsoiler	18
8	Disassembly and withdrawal	19
9	Spare parts for the MGX subsoiler	19

1 Introduction

Congratulations on your purchase of the MGX subsoiler. This manual provides information on hazards that may occur during use, work with the subsoiler, technical data and the most important indications and recommendations, the knowledge and application of which is a prerequisite for proper operation. Keep this manual for future use. If you do not understand any of the provisions of this manual, please contact the manufacturer.

Notes that are important for safety reasons are marked with the following sign:



Machine identification

The identification data of the MGX subsoiler can be found on the data plates placed on the supporting frame, which contains the CE mark, essential information about the manufacturer and the machine:



The warranty for the subsoiler is valid for 12 months from the date of its sale.

The warranty card is an integral part of the machine.

Always quote the serial number when making inquiries about spare parts.

Information on spare parts can be found

- at: <http://mandam.com.pl/parts/>
- by phone +48 668 662 289
- E-mail: parts@mandam.com.pl



1.1 Safety signs



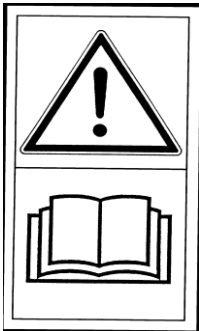

Remember! When using the MGX subsoiler, be especially careful in places marked with special information and warning signs (yellow stickers)

The signs and inscriptions on the machine are listed below. Safety signs and inscriptions should be protected against misplacement and loss of legibility. Misplaced and illegible signs and inscriptions should be replaced with new ones. Information on the acquisition of information and warning signs can be found by contacting the MANDAM spare parts department.

Table 1. Information and warning signs.

Safety sign	Safety sign meaning	Location on the machine
	Read the operating manual before use	The subsoiler frame near the upper connector attachment
	Squashing of the toes or feet	The subsoiler frame near the upper connector attachment
	Stay away from the lift rods when operating	The subsoiler frame near the upper connector attachment

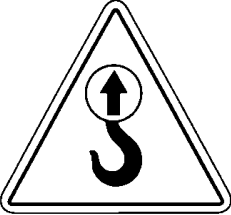
Safety sign	Safety sign meaning	Location on the machine
	<p>Keep a safe distance from folding and movable parts of the machine</p>	<p>The front part of the middle frame near the side frames</p>
	<p>Do not reach into the crush area if components may move</p>	<p>The middle frame near the side frames</p>
	<p>Fluid jet under pressure - body injury</p>	<p>Actuators</p>
	<p>Place of attachment with transport belts</p>	<p>Upper part of the drawbar (upper link pin) The rear part of the frame:</p> <ul style="list-style-type: none"> • Rigid frame (near roller depth adjustment) • folding frame (near actuator pin on center frame)

1.2 Design of the MGX subsoiler

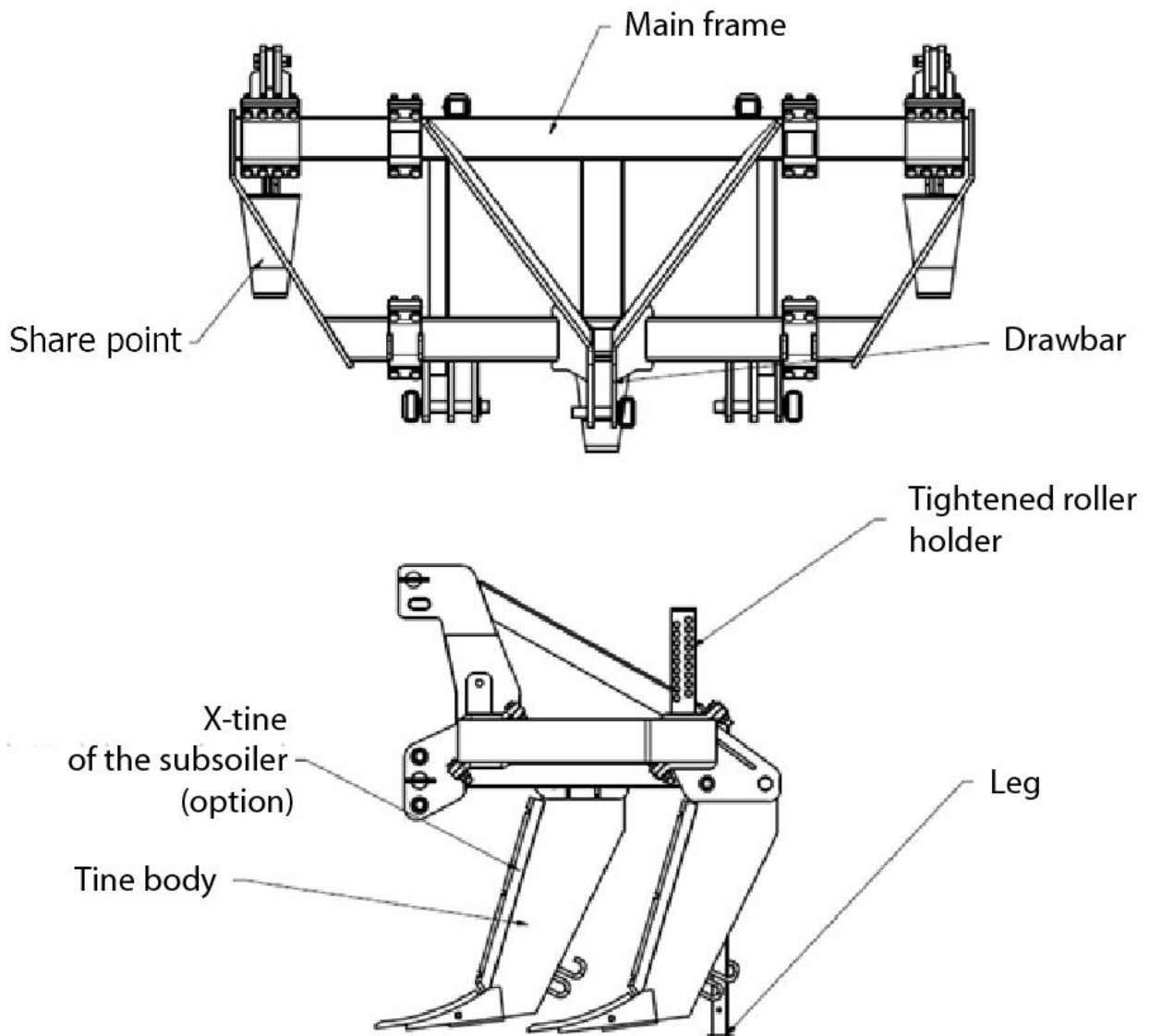

Fig. 1 Design of the MGX subsoiler.

Table 2. Types of the MGX subsoiler.

Type of the subsoiler	Min/Max working width [m]	Number of tines [pcs]	Min. tractor power [HP]	Mass [kg]
MGX 2200	1.50 - 2.20	2/3	120	310
MGX 3000	1.80 - 2.75	4/5	180	360

2 Intended use

The subsoiler is an agricultural machine designed for loosening and aerating soil at a depth of up to 60 cm in order to improve its physical and biological properties. Aeration and irrigation of the lower soil layers obtained thanks to subsoiling ensures an excellent agrotechnical effect, positively affects the development of plants which have a deeper root system. Subsoiling is performed in a given field once every few years -

most often (4-5 years).

A signal that may indicate the need for subsoiling may be water pool in the spring. After subsoiling, there is no need to perform deep plowing, and one can sow plants by using fruiting tools. The MGX subsoiler used immediately before the fruiting treatments has a positive effect on the soil structure and improves the conditions for the development of root crops.



CAUTION! The MGX subsoiler is designed exclusively for soil cultivation. Using it for other purposes will be understood as misuse and will result in the loss of warranty.



CAUTION! Failure to observe the recommendations of this manual will also be understood as misuse. The manufacturer is not liable for damage caused by misuse.

3 General safety rules

The MGX subsoiler may be started, operated and repaired only by persons familiar with its operation and the cooperating tractor as well as with the principles of safe operation and maintenance of the unit. The manufacturer is not responsible for arbitrary changes in the construction of the subsoiler. During the warranty period, only MANDAM factory replacement parts should be used.

The MGX subsoiler should be operated with all precautions, in particular:

- before each start-up, check the machine and the tractor, whether their condition guarantees safety while in motion and during work,
- it is forbidden to use the machine by persons under the age of 16, the sick, and those who have consumed alcohol or other intoxicants,
- wear protective clothes, footwear and gloves during maintenance work,
- the permissible axle loads and transport dimensions must not be exceeded,
- use only original cotter pins,
- do not approach the unit during its lifting, lowering, folding and unfolding,
- do not stay between the tractor and the machine when the engine is running,
- move the subsoiler, raise and lower it slowly and gently without sudden jerks and paying attention that there are no bystanders nearby,
- do not reverse the tractor or make turns with the machine lowered in the operating position,
- do not use the tractor's independent brakes when making turns,
- do not stand on the machine and load it additionally during operation and transport,
- during turns, be especially careful if there are bystanders nearby,
- it is not allowed to operate the unit on slopes greater than 12°,
- perform any repairs, lubrication or cleaning of operating elements only with the engine turned off and the machine lowered,
- during maintenance and replacement of parts, getting under the machine without proper protection may lead to head injuries - in this case, use a helmet,
- during breaks in work, lower the machine to the ground and stop the tractor engine,
- driving and parking the machine on a slope with unstable ground can cause slumping,
- the machine must be stored in a way that prevents injury to people and animals.



WARNING! Failure to comply with the above rules may pose a threat to the operator and bystanders as well as may lead to damage to the machine. The user is responsible for damages resulting from failure to comply with these rules.

3.1 Coupling and uncoupling from the tractor

- Coupling the machine with the tractor should be done in accordance with the recommendations, ensuring to secure the suspension pins with cotter pins.
- When coupling the tractor with the subsoiler, it is forbidden to stay between the machine and the tractor at that time.
- The tractor cooperating with the set must be fully functional. It is forbidden to couple the machine with a tractor with a faulty hydraulic system.
- Remember to maintain the following: balance of the tractor with the attached unit, its steerability and braking ability - the front axle load must not fall below 20% of the tractor's total axle load - a set of front weights.
- In the resting position, the machine disconnected from the tractor should maintain stable balance.

3.2 Tires

- Tire pressure must not exceed the manufacturer's recommended pressure; it is also forbidden to transport with too low of a pressure, which may cause an accident or damage the machine while on large unevenness and driving too fast.
- Significantly damaged tires (especially profile damage) must be replaced immediately
- When changing tires, secure the machine against rolling.
- Repair work on wheels or tires should be performed by persons trained and authorized for this purpose. These works should be performed with the use of appropriately selected tools.
- Each time the wheels are mounted, check the tightness of the nuts after driving 50 km.

3.3 Safety related to transport on public roads

When transporting the machine on public roads, it is mandatory to use a lighting device, marking plate and side reflectors.

Do not exceed the driving speed during transport, which is:

- on roads with a smooth surface (asphalt) up to 25 km/h,
- on field or paved roads 6-10 km/h,
- on bumpy roads no more than 5 km/h.

Driving speed must be adjusted to the quality of the road and its conditions, so that the unit does not jump on the tractor's suspension system. Be especially careful when passing, overtaking and turning. The permissible operating width of the machine on public roads is 3.0 m. It is forbidden to transport the unit in which the slope inclination previous to the unit exceeds 7°.

During transport, the clearance under the machine should be at least 30 cm



WARNING! Failure to comply with the above rules may pose a threat to the operator and bystanders as well as may lead to damaging the machine. The user is responsible for damages resulting from failure to comply with these rules.

Pursuant to road safety regulations (Regulation of the Minister of Infrastructure of 31.12.2002, Journal of Laws No. 32 of 2002, item 262) - the unit consisting of a farm tractor and an agricultural machine coupled with it must meet the requirements identical to those of the tractor.



CAUTION! The unit as a part of the vehicle protruding beyond the rear side outline of the tractor, covering the rear lights of the tractor, poses a threat to other vehicles on the road. It is forbidden to travel on public roads without appropriate markings.

The units should have:

- triangular plate distinguishing slow-moving vehicles,
- two front-facing boards with a white side lamp and a white reflector,
- two rear-facing boards with combined light and red reflector. The boards should be painted with diagonal white and red stripes.

After attaching the boards, connect the electrical wires of the light and warning device to the socket of the tractor's electrical system.

The manufacturer does not provide the machine with warning signs as standard. Warning signs are commercially available. Warning signs should be securely mounted in holders and the plug should be connected to the socket of the tractor's electrical system. Before transport, check the operation of the lights.

After lifting the machine, check the clearance under the lowest operating elements, which should be at least 30 cm.

3.4 Description of the residual risk

MANDAM sp. z o. o. makes every effort to eliminate the risk of an accident. However, there is a residual risk that may result in an accident. The greatest danger occurs in case of:

- use of the machine for purposes other than those described in the manual,
- use of the machine by minors without permission, the sick and those who have drunk alcohol or used other intoxicants,
- presence of people and animals within the operating range of the machine,
- failure to exercise caution during transport and maneuvering the tractor,
- staying on the machine or between the machine and the tractor when the engine is running,
- operation without observing the operating instructions,
- moving on public roads.

3.5 Assessment of the residual risk

Residual risks can be reduced by following the recommendations presented below:

- careful and unhurried operation of the machine,

- careful reading of the operating manual,
- keeping a safe distance from dangerous zones,
- prohibition on staying on the machine and in the machine operating zones when the tractor engine is running,
- performing maintenance works in accordance with safety rules,
- using protective clothes, and in the case of work under the machine also a helmet,
- protecting against access to machines by unauthorized persons, especially children.

4 Handling and Usage Information

The subsoiler is usually delivered to the customer ready for operation, however, before starting work, the technical condition of the unit should be checked, especially the condition of the operating elements and screw connections. During the inspection, the subsoiler should be secured against tipping over with properly set support legs (they are standard equipment of the subsoiler). Loose screw connections must be tightened.

During the operation of the machine, the following may be adjusted:

- operating depth of tines - by changing the position of the supporting roller in the adjustment handles.
- spacing of operating tines of the subsoiler.

If a subsoiler with supporting roller is purchased, its subassemblies must be assembled during the first preparation of the unit for work. To this end, set the subsoiler on a flat hardened ground, in a place that allows the roller to maneuver. First of all, mount the tightened holder of the roller arms in the right place. To transport the roller, use a lifting device with a lifting capacity of at least 500 kg due to stability during transport. Set the arms in the subsoiler holders and connect the arms with the roller clamp with screws (fig. 2).

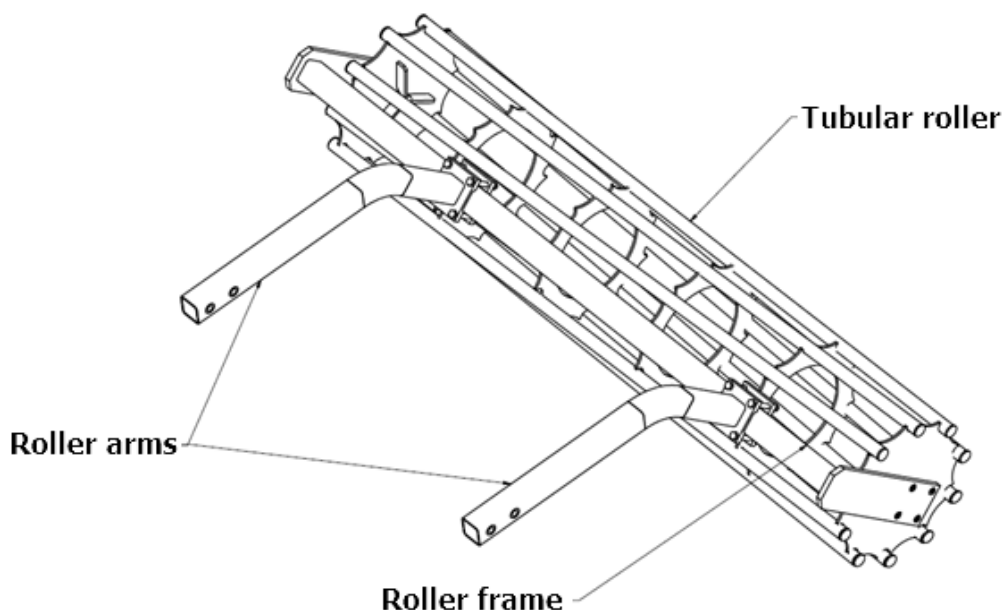

Fig. 2 Connection of the arms with the roller clamp.

Before starting work, the technical condition of the subsoiler should be checked, especially the condition of the operating elements and screw connections.



CAUTION! The correct procedure for assembling the rollers in the arm holders requires the screw to be evenly tightened diagonally so that the entire plane of the arm holders is adjacent to the plane of the roller clamp profile. This is the most reliable way to connect the roller arms to the machine!

The subsoiler also has adjustable spacing of operating tines. It allows to adjust the width of the field subsoiling. The adjustment is made by loosening the M20 screws in the tine holder, and then moving the tine along the frame profile to the desired position. After setting all the tines, the loosened screws of the tine holder must be tightened again.

Table 3. Range of operating tines spacing of the MGX subsoiler.

Type of the subsoiler	Minimum working width [mm]	Maximum working width [mm]	Number of tines
MGX 2200	1500	2200	3
MGX 3000 (4z)	1800	2750	4
MGX 3000 (5z)	2200	2750	5

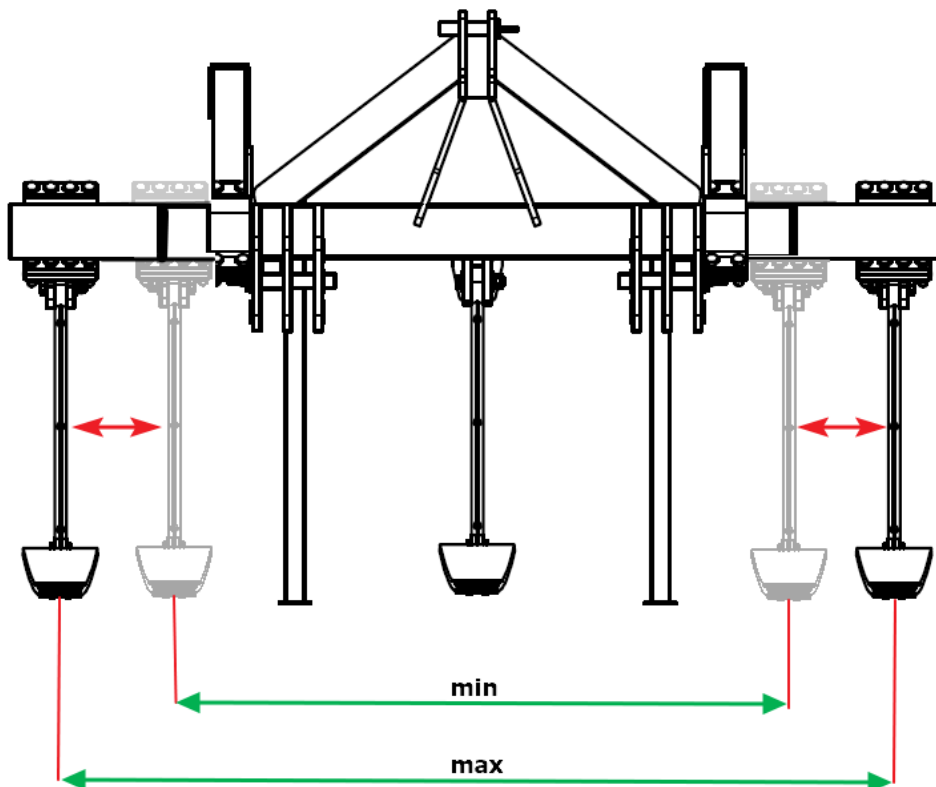

Fig. 3 Design of the MGX subsoiler.



**WARNING! Operating the subsoiler on excessively moist soil is unacceptable.
Operating on stony soil with large stones is unacceptable!**

Optionally, it is possible to mount a weight with a chain behind the subsoiler's tine (fig. 4), whose main task is to create a groove (drainage) at the operating depth of the machine, which ensures the circulation of water moving after rainfall.



Fig. 4 "Mole" – a weight with chain.

4.1 Handling and Usage Information

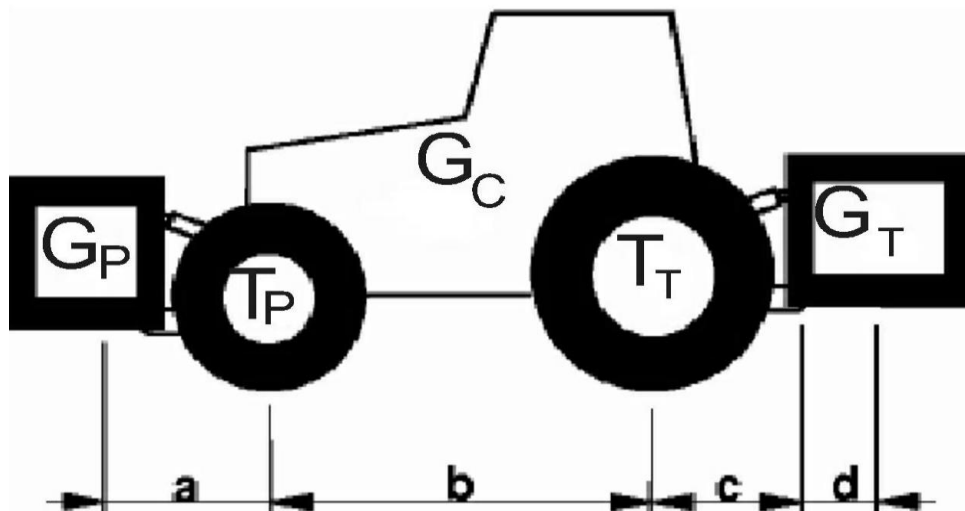

Fig. 5 Scheme of tractor load designations.

Axle load calculations

Designations:

- G_C - deadweight load of the tractor,
- T_P - front axle load of an empty tractor,
- T_T - rear axle load of an empty tractor,
- G_P - total weight of the rear-mounted device,
- G_T - total weight of the front-mounted device,

a - distance between the center of gravity of the front-mounted device and the center of the axle,
 b - tractor wheel track,
 c - distance between the center of the rear axle and the center of the coupling pin of the rear unit,
 d - distance of the center of gravity of the machine from the tractor's coupling pins (mounted machine - 1.5 m, semi-mounted machine - 3 m and 0.7 weight),
 x - distance of the center of gravity from the rear axle (if the manufacturer does not specify, enter 0.45).

Minimum front load when coupled to the rear:

$$G_{Pmin} = \frac{G_T \cdot (c+d) - T_P \cdot b + 0,2 \cdot G_C \cdot b}{a+b}$$

Actual front axle loads

$$T_{Pcat} = \frac{G_P \cdot (a+b) + T_P \cdot b - G_T \cdot (c+d)}{b}$$

Actual total weight

$$G_{cat} = G_P + G_C + G_T$$

Actual rear axle load

$$T_{Tcat} = G_{cat} - T_{Pcat}$$

4.2 Coupling the subsoiler with the tractor

The tire pressure of the tractor wheels should be compliant with the manufacturer's recommendations. The lower links of the three-point suspension system should be at the same height, in the spacing corresponding to the spacing of the lower suspension points. When coupling the machine to the tractor, the unit must stand on a hard and even surface.

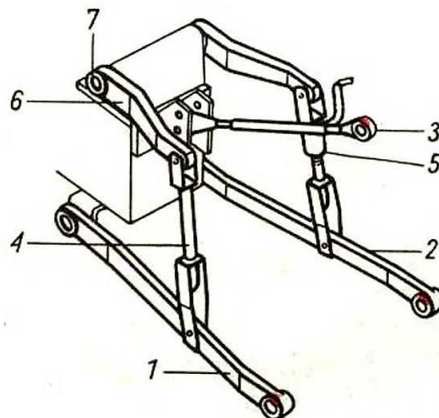

Fig. 6 Three-point suspension system of the tractor: 1,2 - lower rods, 3 - upper link, 4 - left hanger, 5 - right hanger with adjustable length, 6 - lifting arm, 7 - lifting roller

When attaching the MGX subsoiler to the tractor, perform the following actions:

- switch the tractor's hydraulic system to position regulation,
- remove the lower coupling pins if the tractor's three-point suspension system is not equipped with coupling hooks,
- carefully reverse, hang the machine on the lower links, then secure,
- connect the upper link of the tractor (in units not equipped with a trolley) - during the operation of the unit, the attachment point of the upper link on the machine should be higher than the attachment point of this link on the tractor,
- check lifting, lowering of the subsoiler and operation of all systems

Each tractor cooperating with the machine must be equipped with a set of weights and maintain controllability in transport, i.e. at least 20% of the tractor's weight must be loaded on its front axle.

4.3. Maintenance and lubrication

- Each time after finishing work, the subsoiler should be cleaned of soil, and then parts and assemblies should be inspected. **Otherwise, if the rollers get stuck to the soil, resulting in additional load, there may be problems with the operation of the machine!**
- After the first 4 hours of operation, retighten all screws and then periodically check tightness. **Failure to do so will cause the play to deepen and result in damage to the machine.**
- Lubricate the grease points on the hinge pins daily during the life of the machine. Bearings of the tubular roller and leveling discs should be lubricated every 25 working hours (does not apply to bearings of maintenance-free discs - these bearings do not require maintenance and lubrication).
- When replacing worn parts, use thread locker, original screws and nuts.
- Always remember to tighten the screw connections properly.

CAUTION! Periodic lubrication is a guarantee of machine durability.

The durability and efficiency of the machine largely depends on regular lubrication. Use mineral lubricants for lubrication. Lubrication points must be thoroughly cleaned before pressing or applying grease.



CAUTION! It is forbidden to work on a damaged machine caused by any event that resulted in cracking or deformation of the frame, roller or other machine assembly!

4.4. Screw tightening torque

Screws and nuts should be tightened in the machine with the appropriate torque depending on the strength class of the screw and its size and thread pitch. The appropriate tightening torque values are shown in table 4.

Table 4. Tightening torque values for screws and nuts.

Tightening torques of screws and nuts [Nm]					
		Thread pitch	Screw strength class		
			8.8	10.9	12.9
Dimension	M4	0,7	3,2	4,5	5,2
	M5	0,8	6	8,4	10
	M6	1,0	11	15	17
	M8	1,3	27	34	40
		1,0	21	30	35
	M10	1,5	46	65	76
		1,3	41	75	67
		1,0	36	50	59
	M12	1,8	79	111	129
		1,3	65	91	107
	M14	2,0	124	174	203
		1,5	104	143	167
	M16	2,0	170	237	277
		1,5	139	196	228
	M18	2,0	258	363	422
		1,5	180	254	296
	M20	2,5	332	469	546
		1,5	229	322	375
	M22	2,5	415	584	682
		1,5	282	397	463
	M24	3,0	576	809	942
		2,0	430	603	706
	M27	3,0	740	1050	1250
		2,0	552	783	933
	M30	3,5	1000	1450	1700
		2,0	745	1080	1270
	M36	4,0	1290	1790	2020
		2,0	960	1340	1500

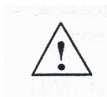

CAUTION! It is forbidden to work on a damaged machine caused by any event that resulted in cracking or deformation of the frame, roller or other machine assembly!

5 Service

Due to the simplicity of its design and the materials used, the MGX subsoiler is distinguished by a very low failure rate. To maximize uptime, follow all instructions in this manual for operation, adjustment, lubrication, transportation, and storage of the machine.

5.1 Daily service

- Each time after finishing work, the MGX subsoiler should be cleaned of soil, and then parts and assemblies should be inspected. When cleaning, remove soil and plant debris.
- After the first 4 hours of operation, retighten all screws and then periodically check tightness.
- Worn out elements should be replaced with original new ones.
- When replacing worn parts, use thread locker, original screws and nuts.
- Always remember to tighten the screw connections properly.



CAUTION! Periodic lubrication is a guarantee of machine durability.



CAUTION! During maintenance works and replacements, the unit should be secured against rolling. It should be connected to the tractor with the parking brake on and the tractor engine should be turned off. Use the correct spanners and protective gloves during maintenance and repairs, and a helmet if necessary.

5.2 Off-season service

After the end of the working season, the subsoiler should be thoroughly cleaned, the damage to the paint coating should be repaired, and the worn surfaces of the tines, frame, strings and roller rings, as well as the threads of the adjusting screws should be washed with “Antykor” kerosene and protected against corrosion with “Antykor 1” grease, moreover full lubrication must be carried out. During a break in operation, it is recommended to store the machine under a roof. However, if this is not possible, check the condition of the protection from time to time and, if necessary, replenish the grease washed away by rain.

5.3 Servicing the support wheel assembly

Check tire pressure regularly. In the event of a significant loss of air from the tires, check the tightness of the air valve. Then take the wheel to a specialized workshop to locate and repair the damage. Significantly damaged tires (especially profile damage) must be replaced immediately.

6 Replacement procedures

Replacing the tubular roller bearings

If the bearings are damaged, replace them as follows:

- place the machine on an even surface,
- unscrew the four screws securing the ball bearings on each side,
- remove the tubular roller,
- loosen both headless screws in each of the bearings and remove the bearings with a puller,
- put new bearings loosely on the roller,
- roll the roller between the bearing plates and screw the bearings to them. Tighten the headless screws using anti-loosening adhesive.

Replacement of operating elements

Excessively worn operating elements make it difficult to penetrate the tools and cause an increase in operating resistance.

Replacement of working elements should be carried out with the machine lowered to the ground, after switching off the tractor engine. To prevent the replaced elements from touching the ground, place durable pads (e.g. wooden blocks with a thickness of approx. 20 cm under the adjacent operating elements or the roller). After lowering the subsoiler, switching off the tractor engine and pulling the handbrake, check the stability of the tractor-machine unit. Only standard screws should be used to fasten new elements.

In the case of repeated disassembly of the machine components, it is necessary to check and, if necessary, replace the connecting elements, such as screws, washers or nuts, whose excessive wear may lead to uncontrolled loosening of the connected elements, and consequently their damage.

When working with extremely worn working tools, such work can cause permanent damage to all machine assemblies. Tools should be replaced when their wear exceeds the values specified in the manual. If the instructions are not followed, damage may occur for which the manufacturer is **NOT RESPONSIBLE!**

Replacement of actuators

A malfunctioning actuator, unsealing, etc. should be replaced, dismantled and sent to a specialist workshop. Actuators should be replaced with the machine disassembled. Connect the actuator to the system and, mounted on one side it should cycle several times in order to completely fill the actuator with oil. Otherwise, the lowering section may fall suddenly.



CAUTION! During repairs and maintenance, the machine should be lowered to the ground and supported on supports ensuring full stability, and the tractor engine should be turned off. Use the correct spanners and protective gloves during maintenance and repairs.

7 Storage of the subsoiler

The subsoiler should be stored under a roof. In the absence of a roof, it is allowed to store the machine outside.

The subsoiler should be stored in a place that does not pose a threat to people and the environment. In the case of long-term storage of the machine outside, maintenance of operating elements should be repeated when the preservative layer is rinsed off. After disconnecting from the tractor, the machines should be supported on a hard and even ground, maintaining permanent balance. All operating assemblies should rest on the ground. The machine should be lowered so as to avoid impacts of operating elements on hard ground. After lowering the machine, disconnect the suspension system and drive the tractor away. Also, elements removed from the machine should be stored firmly supported on the ground, excluding the possibility of uncontrolled movement. It is recommended to store the machine in paved and roofed places, inaccessible to unauthorized persons and animals.



Store the machine firmly supported on a hard surface in a way that prevents injury to people or animals

8 Disassembly and withdrawal



CAUTION! When disassembling the machine, take all precautions using efficient tools and personal protective equipment. Disassembled parts should be disposed of in accordance with the requirements of environmental protection.

The unit used in accordance with the rules specified in the operating manual is durable for many years, but worn or damaged elements should be replaced with new ones. In the case of accidental damage (significant cracks and deformations of the frames) that deteriorate the quality of the machine's operation and pose a threat to its further exploitation, the machine must be withdrawn from use.

Disassembly of the machine should be carried out by persons previously familiar with its construction. These activities should be performed after placing the machine on an even and hard surface. Disassembled metal parts must be scrapped.

9 Spare parts for the MGX subsoiler

To find, price and order original spare parts for MANDAM machines, please visit our website at: www.mandam.com.pl, in the "parts" tab.

On this website, we provide catalogs and spare parts cards in PDF format, containing current diagrams of parts for each machine, along with their numbers and prices.

Orders for parts or inquiries regarding them can be placed directly from this website (tab: "contact/order"), or by e-mail to the following address: parts@mandam.com.pl

The order should contain part numbers and their quantities, as well as details of the ordering party/payer along with a contact telephone number.

Parts are shipped directly to the address provided, and payment is made on delivery.

In case of any ambiguities, please contact the Mandam spare parts department at the following telephone numbers: +48-32-232-2660 ext. 39 or 45, or mobile +48 668-66-22-89.

Original MANDAM spare parts are also available from all authorized distributors of MANDAM machines.