

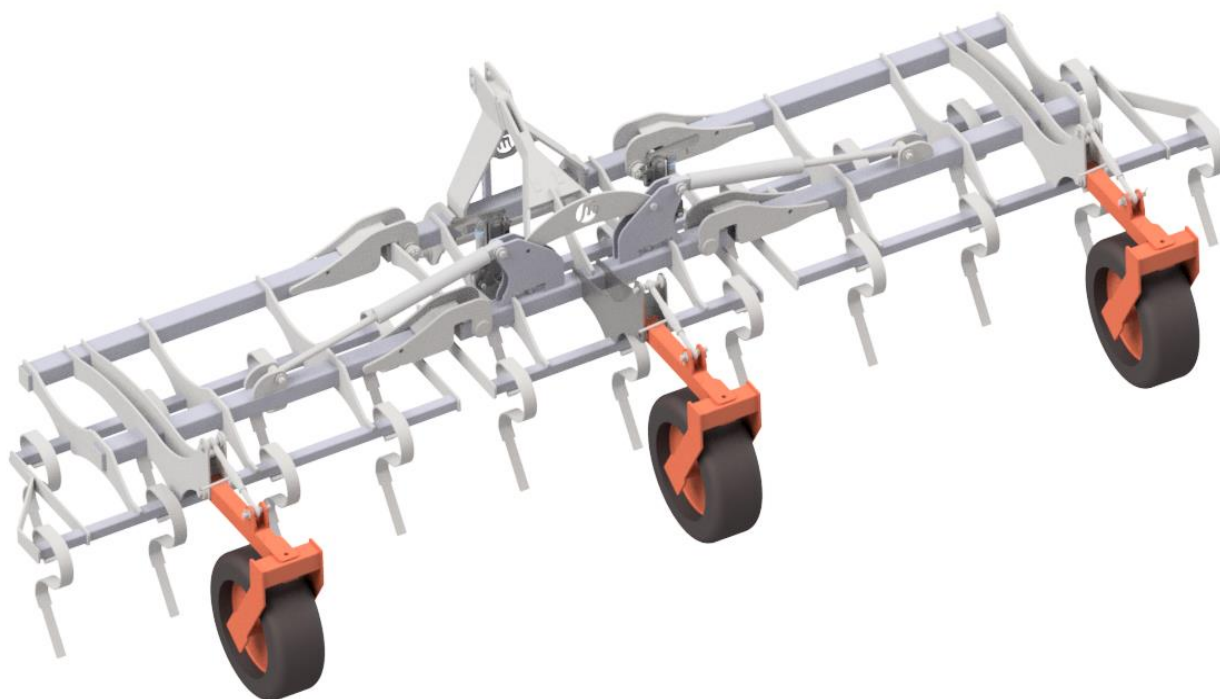

MANDAM Sp. z o.o.
ul. Toruńska 14, 44-100 Gliwice, Poland
e-mail: mandam@mandam.com.pl
Tel.: 032 232 26 60 Fax: 032 232 58 85
NIP (VAT no.): 648 000 16 74 REGON (Registration no.): P - 008173131

INSTRUCTION MANUAL

FRONT cultivator



Issue II
Gliwice 2022



DECLARATION OF CONFORMITY



FOR A MACHINE

In accordance with the Ordinance of the Minister of the Economy dated 21 October 2008 (Journal of Laws No. 199, item 1228)
and the Directive of the European Union no. 2006/42/EC of 17 May 2006

MANDAM Sp. z o.o.

ul. Toruńska 14

44-100 Gliwice

hereby declares at its sole responsibility that the following machine:

FRONT CULTIVATOR

type/model:

year of manufacture:

serial number:

under this declaration, complies with:

the **Ordinance** of the Ministry of Economy of 21 October 2008 on fundamental requirements for machinery (Journal of Laws No. 199, item 1228)
and the **Directive** of the European Union 2006/42/EC of 17 May 2006.

The persons responsible for the technical documentation for the machine: Jarosław

Kudlek, Łukasz Jakus

ul. Toruńska 14, 44-100 Gliwice, Poland

For assessment of compliance the following standards have been applied:

PN-EN ISO 13857:2010

PN-EN ISO 4254-1:2016-02

PN-EN ISO 12100-1:2005/A1:2012

PN-EN ISO 12100-2:2005/A1:2012

PN-EN 982+A1:2008

This EC Declaration of Conformity shall be cancelled
if the machine is modified or redesigned without consent of the manufacturer.

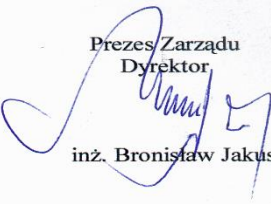
Prezes Zarządu
Dyrektor

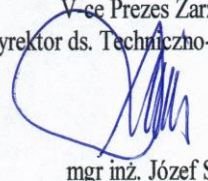
inż. Bronisław Jakus

Wice Prezes Zarządu
Dyrektor ds. Techniczno-Organizacyjnych

mgr inż. Józef Seidel

.....
Place and date of issue

.....
First and last name, position held
and signature of the person authorized

1. Introduction	4
1.1. Safety symbols and inscriptions	5
2. General information	7
2.1. Design of the FRONT cultivator	7
2.2. Intended use	8
3. General safety information	8
3.1. Proper hitching and unhitching the cultivator from the tractor	9
3.2. Hydraulic system	9
3.3. Transport safety on public roads	9
3.4. Residual risk description	10
3.5. Residual risk assessment	10
4. Information on operation and use	11
4.1. Before using the cultivator	12
4.2. Hitching the cultivator with the tractor	12
4.3. Operation and adjustment	13
4.3.1. Automatic locking of the machine side extensions	13
4.3.2. Implement opening sequence	14
4.3.3. FRONT cultivator working depth	17
4.4. Rules for transporting the cultivator on public roads and lighting the implement	17
4.5. Maintenance and lubrication	18
4.6. Screw tightening torque	19
5. FRONT cultivator maintenance	20
5.1. Hydraulic system maintenance	20
6. Replacement procedures	20
7. FRONT cultivator storage	21
8. Disassembly and withdrawal from service and scrapping	22
9. FRONT cultivator – spare parts	23

1. Introduction

Congratulations on your purchase of the FRONT cultivator.

This instruction manual provides information on the hazards that may occur during use, cultivator operation, technical data and the most important indications and recommendations, the knowledge and use of which is a prerequisite for proper operation. Keep this manual for future reference. Should you have any problems with understanding any statement in the instruction manual, please contact the manufacturer.

The following mark indicates the guidelines that are important due to safety reasons:



Machine identification

Identification data of the cultivator can be found on the rating plates placed on the load-bearing frame. The rating plate contains the CE mark, basic information about the machine and the manufacturer:



The warranty for the cultivator is valid for 12 months from the date of sale.

The warranty card constitutes an integral part of the machine.

Whenever you request any information on spare parts, provide the serial number.

For more information on spare parts,

- please visit our website at: <http://mandam.com.pl/parts/>
- call us at +48 668 662 289
- e-mail: czeski@mandam.com.pl

1.1. Safety symbols and inscriptions







CAUTION! Special care must be taken when using the machine in case of areas marked with special information and warning signs (yellow stickers).

The following symbols and inscriptions can be found on the implement. Secure the symbols, signs and inscriptions against loss and make sure they are legible at all times. If lost and illegible, replace the symbols, signs and inscriptions with new ones.

Table 1. Information and warning signs

<i>Safety sign</i>	<i>Meaning of the safety sign</i>	<i>Location on the implement</i>
	Read the instruction manual prior to operating the implement.	Frame adjacent to the mounting place of the upper fastener
	Danger of toe or foot crush	Frame adjacent to the mounting place of the upper fastener
	Keep clear from lift bars while controlling the lift	Frame adjacent to the mounting place of the upper fastener

Safety sign	Meaning of the safety sign	Location on the implement
	<p>Keep clear from foldable and moving parts of the implement</p>	<p>Front part of the central frame adjacent to side frames</p>
	<p>Do not reach into the crushing zone if the elements can move</p>	<p>Central frame adjacent to side frames</p>
	<p>Pressurized fluid - hazard of bodily injury</p>	<p>Cylinders</p>
	<p>Fixing point for transport belts</p>	<p>Upper part of the drawbar (upper fastener bolt) Rear part of the frame:</p> <ul style="list-style-type: none"> • rigid frame (adjacent to the roller depth adjustment) • foldable frame (adjacent to the cylinder bolt on the central frame)

2. General information

2.1. Design of the FRONT cultivator

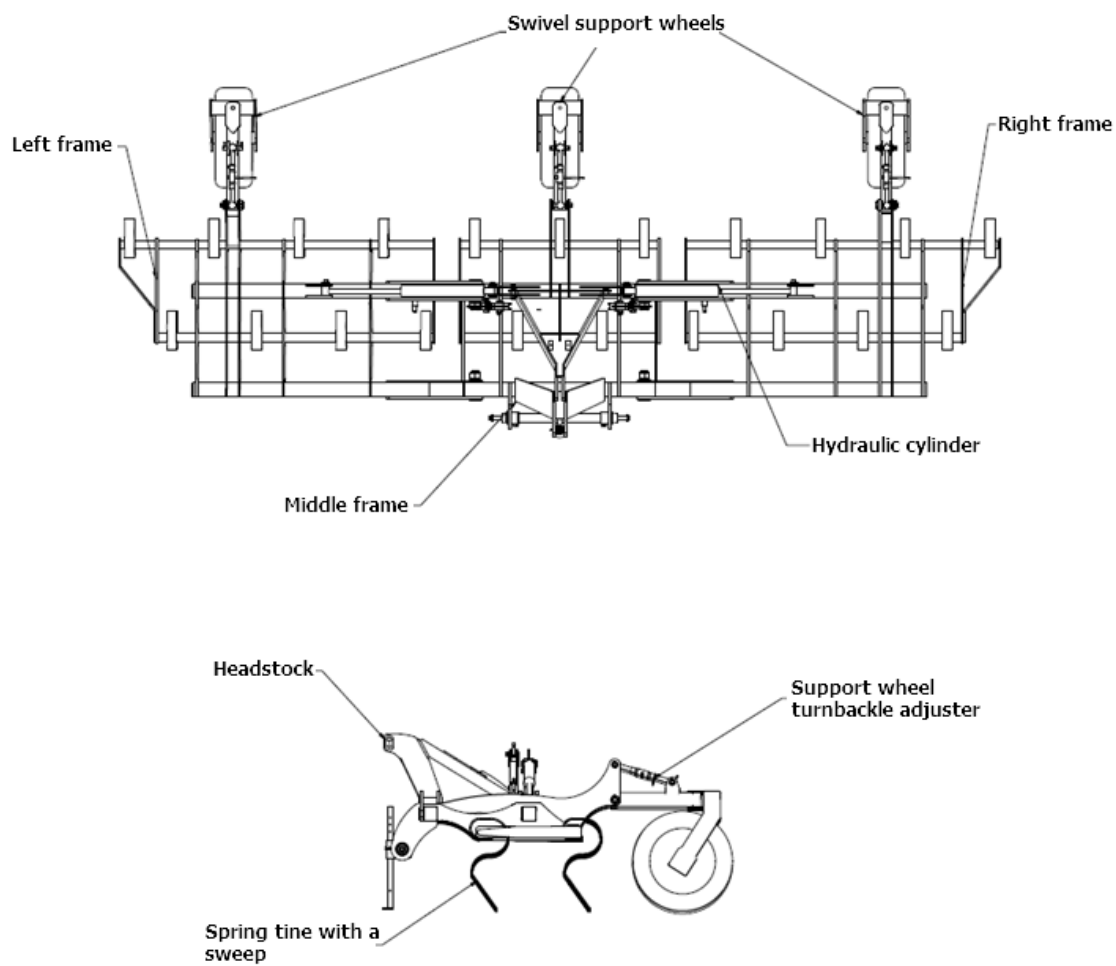

Fig. 1 Design of the FRONT cultivator

Table 2. FRONT cultivator types

Cultivator type	Working width [m]	Number of tines [pcs]	Min. tractor power [hp]	Weight [kg]
FRONT 3.0	3.00	11	70	750
FRONT 3.5	3.50	12	80	875
FRONT 4.0	4.00	13	110	1000
FRONT 4.0 H	4.00	13	110	1100
FRONT 4.5 H	4.50	15	120	1150
FRONT 5.0 H	5.00	17	130	1250
FRONT 6.0 H	6.00	21	150	1400

2.2. Intended use

The cultivator is designed to work at depths of 5-15 cm. It is designed to cut the stubble accurately across its entire width and mix the plant residues. The FRONT cultivator can be used for post-harvest cultivation as well as for pre-sowing. The cultivator is suspended from the tractor's front three-point hitch. With the cultivator hitched from the front of the tractor, the rear three-point hitch can be used for other applications at the same time.

The workpieces are 70x12 spring tines mounted on 2 rows of transverse beams. The spring tine can be equipped with a sweep or ALL X coulters.



CAUTION! The cultivator is designed for agricultural use only for soil cultivation. Using the implement for tasks that differ from the intended use shall be regarded as misuse, resulting in loss of warranty.



CAUTION! The manufacturer shall not be liable for any damage arising out of misuse. Failure to follow the guidelines included in this instruction manual shall also be regarded as misuse.

3. General safety information

The FRONT cultivator can only be started, used and repaired by persons familiar with its operation and that of the tractor being used and the rules for its safe use and operation.

The manufacturer shall not be liable for any unauthorised alternation of the cultivator.

Only genuine MANDAM spare parts shall be used during the warranty period.

The cultivator must be operated with all precautionary measures, in particular:

- each time before starting operation check the machine and the tractor whether their condition guarantees safety during operation and travel,
- minors, disabled or intoxicated persons (under the influence of alcohol or drugs) must not operate the machine,
- wear work clothes, shoes and gloves during maintenance,
- do not exceed the maximum axle loads, tyre pressure and transport dimensions,
- use only original cotter pins and pins,
- do not approach the cultivator when it is being lifted or lowered,
- do not stay between the tractor and the cultivator when the engine is running,
- start the machine, drive, lift and lower it slowly and smoothly, without sudden

- jerks, making sure that nobody stays in the vicinity,
- do not reverse and make U-turns when the implement is lowered to the working position;
- when making U-turns do not use independent tractor brakes;
- during the operation and travel do not stand on the implement and do not put additional loads onto it;
- while making U-turns, pay due caution if anyone is in the vicinity,
- do not operate the cultivator on slopes with the inclination exceeding 12° ,
- any repairs, lubrication or cleaning of working components may be performed as long as the engine is not running and the cultivator is lowered,
- there is a hazard of head injury when you perform maintenance or replacement of parts under the implement without adequate protection - wear a hardhat,
- during a break in the work, always lower the implement to the ground and stop the tractor engine,
- the cultivator is equipped with a mechanical lock which blocks the side frames and prevents uncontrolled lowering during transport,
- driving and parking the implement on an unstable slope may cause soil slipping,
- store the implement in a manner preventing injury to people and animals.

3.1. Proper hitching and unhitching the cultivator from the tractor

- Make sure that the machine is hitched to the tractor in accordance with the instructions, use pins and protect the suspension pins with cotter pins.
- While hitching the tractor with the cultivator, do not stay between the implement and the tractor;
- The tractor used together with the cultivator must be fully functional and in good working order. Do not attach the implement to a tractor with a malfunctioning or defective hydraulic system.
- Remember to observe the following: balance of the tractor and the cultivator, tractor steerability and braking performance - the front axle load must not drop below 20% of the total tractor load - a kit of front weights;
- In the rest position the implement unhitched from the tractor shall maintain a stable balance.

3.2. Hydraulic system

The hydraulic system operates under high pressure. Take all precautionary measures, in particular:

- do not connect and disconnect hydraulic hoses when the tractor hydraulic system is pressurised (hydraulics set to neutral position),
- check regularly the conditions of connections and hydraulic hoses,
- do not use the cultivator until the hydraulic system is repaired.

3.3. Transport safety on public roads

For transport, fold the side frames into the transport position. Before folding, the machine must be lifted sufficiently high until the folded side sections do not collide with the ground. The side frames are automatically locked to prevent their opening. The rollers in the side frame sections should then be retracted inside the implement by fully retracting the hydraulic cylinders.

The clearance under the implement during the drive shall be at least 30 cm.

While driving on public roads, it is absolutely mandatory to use lights, an identification

sign for slow-moving vehicles and reflective side lights.

Do not exceed the maximum travel speeds:

- up to 20 km/h on smooth (asphalt) roads,
- 6-10 km/h on dirt roads or cobblestones,
- up to 5 km/h on bumpy roads.

Adapt the drive speed to the road conditions to prevent the cultivator jumping on the three-point hitch and to prevent excessive loads on the implement frame and the three-point hitch.

Maintain particular caution when passing and overtaking and on bends. The maximum implement width on public roads is 3.0 m.

Do not drive with the implement if the slope is inclined crosswise to the implement by more than 7°.



Warning! Failure to observe the above rules may pose hazard to the operator and other people and can lead to the implement damage. The user shall be liable for any damage caused by failure to observe the rules.

3.4. Residual risk description

Mandam Sp. z o.o. makes every effort to eliminate the risk of accidents. However, there is some residual risk that may cause an accident. The biggest hazard occurs when/during:

- using the implement for purposes other no described in the manual,
- operating the implement by people who are underage and do not have licences, are ill or intoxicated,
- presence of people and animals within the implement operating range,
- precautionary measures are not taken during transport and maneouvering with the tractor,
- anyone gets between the implement and the tractor while the tractor's engine is running,
- during operation when operation guidelines are not followed,
- driving on public roads.

3.5. Residual risk assessment

The residual risk can be minimised by applying the following recommendations:

- operate the implement carefully and without undue haste,
- read the instruction manual carefully,
- keep a safe distance from hazard zones,
- do not stay on the implement and within the implement operating range when the engine is running,
- perform the maintenance in accordance with safety rules,
- wear safety clothes and a safety helmet while working under the implement;
- prevent the access of unauthorised personnel and especially children to the implement.

4. Information on operation and use

Before the machine is put into operation for the first time:

- read the instruction manual,
- make sure that the machine is in proper operating condition,
- check the condition of the hydraulic and pneumatic system (replace damaged components, e.g. pressure hoses),
- make sure that the hydraulic hose quick-connectors of the machine match the tractor sockets,
- check the tightening of bolts and nuts,
- check if the air pressure in tyres is according to the manufacturer's recommendations,
- make sure that all components requiring lubrication are lubricated,
- make that the pressure in the tractor wheels is the same on all axles to ensure smooth operation.



CAUTION! The permissible loads on the axles and tyre load capacities must not be exceeded. The front axle load may not be less than 20%.

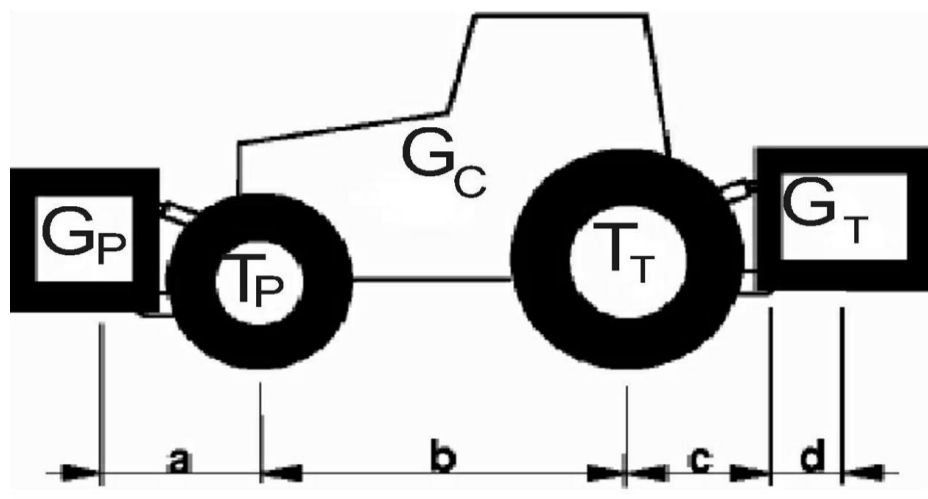

Axle load calculations

Key:

GC - tractor weight,

TP - front axle load for the unhitched tractor,

TT - rear axle load for the unhitched tractor,

GT - total weight of the equipment attached at the back,

GP - total weight of the front-mounted machine,

a - distance between the centre of gravity of the front-mounted equipment and the axle centre,

b - tractor wheelbase,

c - distance between the rear axle centre and the centre point of the hitching pin of the

rear-mounted implement,

d - distance of the centre of gravity of the agricultural implement from the hitching pins of the tractor,

x - distance of the centre of gravity from the rear axle (assume 0.45 if the manufacturer does not provide this parameter).

Minimum load at the front in case of a rear-mounted implement:

$$G_{Pmin} = \frac{G_T \cdot (c+d) - T_P \cdot b + 0,2 \cdot G_C \cdot b}{a+b}$$

Actual load on the front axle:

$$T_{Pcal} = \frac{G_P \cdot (a+b) + T_P \cdot b - G_T \cdot (c+d)}{b}$$

Actual total weight:

$$G_{cal} = G_P + G_C + G_T$$

Actual load on the rear axle:

$$T_{Tcal} = G_{cal} - T_{Pcal}$$

4.1. Before using the cultivator

The FRONT cultivator is usually delivered for sale in a ready-to-operate condition. Due to the limitations of the means of transport, it is also possible to deliver it in a partially disassembled condition - this usually involves disconnecting the support wheel assembly. When preparing the unit for operation for the first time, the support wheel assemblies must be installed to the side frames with pins. Prior to operation check the technical condition of the cultivator, in particular that of the working parts and screw connections.

4.2. Hitching the cultivator with the tractor

Tyre pressure in the tractor wheels must comply with the values recommended by the manufacturer. The lower bars of the three-point hitch should be at the same height, spaced correspondingly to the spacing of the lower points of hitch. While attaching the cultivator to the tractor, the machine must be placed on a hard ground.

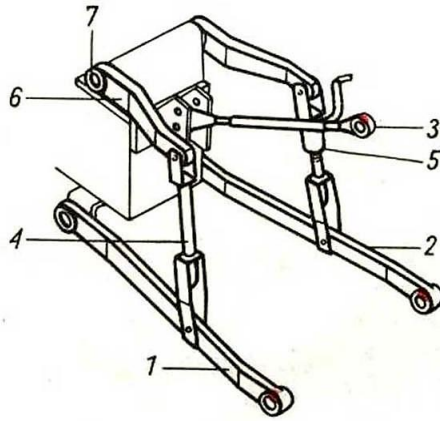

Fig. 2 Three-point hitch of the tractor: 1,2 - lower bars, 3 - upper fastener, 4 - left support rail, 5 - right support rail with adjustable length, 6 - lift arm, 7 - lift shaft

While attaching the cultivator to the tractor, complete the following steps:

- switch the hydraulic system into adjustment position,
- remove lower hitch bolts (if the tractor lift is not equipped with hooks),
- reverse carefully, suspend the implement on the lower bars and secure,
- attach the tractor upper fastener.
- check the operation of cultivator lifting, lowering and the hydraulic system.

4.3. Operation and adjustment

Pre-set the positions of the individual working units in the FRONT cultivator before working in the field. Also level the implement lengthwise with the tractor upper fastener and laterally with the support rail of the right lower bar. Then, make the first work passage to set the optimum working speed and to correct the adjustment based on an assessment of the correct operation of the individual units. The operating speed should be 8 - 12 km/h. In a well-adjusted machine, the frame must be parallel to the ground and all working units must be equally recessed in the soil over the entire working width.

4.3.1. Automatic locking of the machine side extensions

On machines with folding sections, an automatic lock is available that requires no additional operation. The lock uses a mechanism consisting of a cylinder, a hook and a spring (Fig. 3).

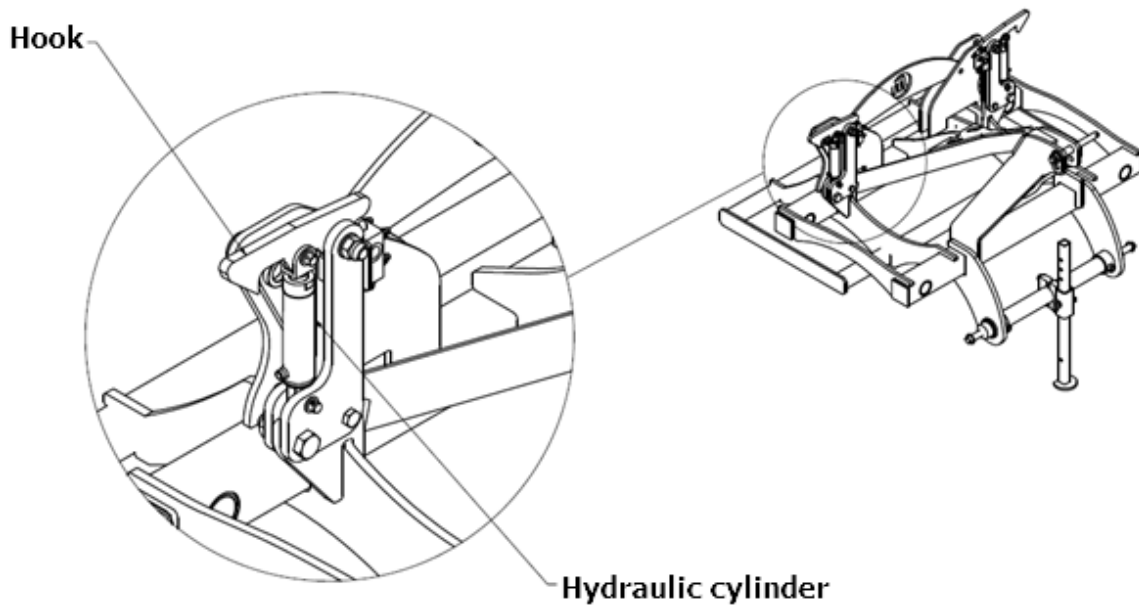

Fig. 3 Main frame with automatic side extensions locking mechanism

4.3.2. Implement opening sequence

Before unfolding the folding side the extensions of the machine, learn the opening sequence to perform this operation correctly.

1. First, raise the implement as much as possible to be able to fold it correctly, avoiding the risk of the folding arms snagging on the ground during movement (Fig. 4).
2. Next, fold the implement side extensions hydraulically into the “closed” position to ensure that the side extension lock mechanism will unlock and allow the implement arms to be opened at a later stage. This operation is necessary each time the arms are opened (Fig. 4).

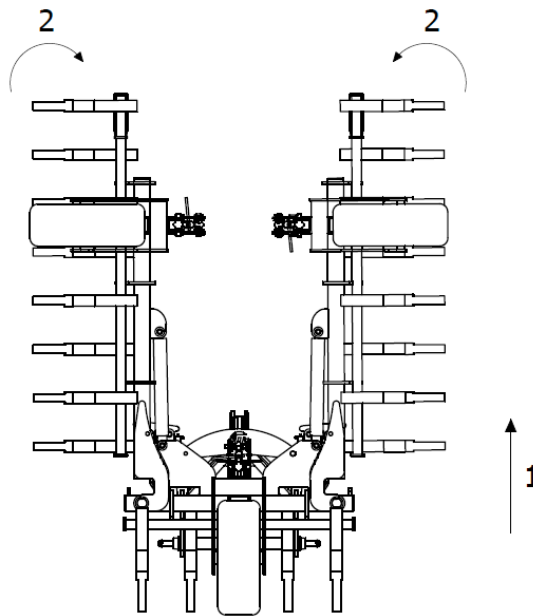

Fig. 4 Implement opening sequence: 1- raise the implement up to the maximum, 2- fold the side extensions into the “closed” position.

3. Then, after making sure that the hook of the hydraulic side extension lock mechanism allows the machine side extensions to be unlocked, proceed to open them fully (Fig. 5).

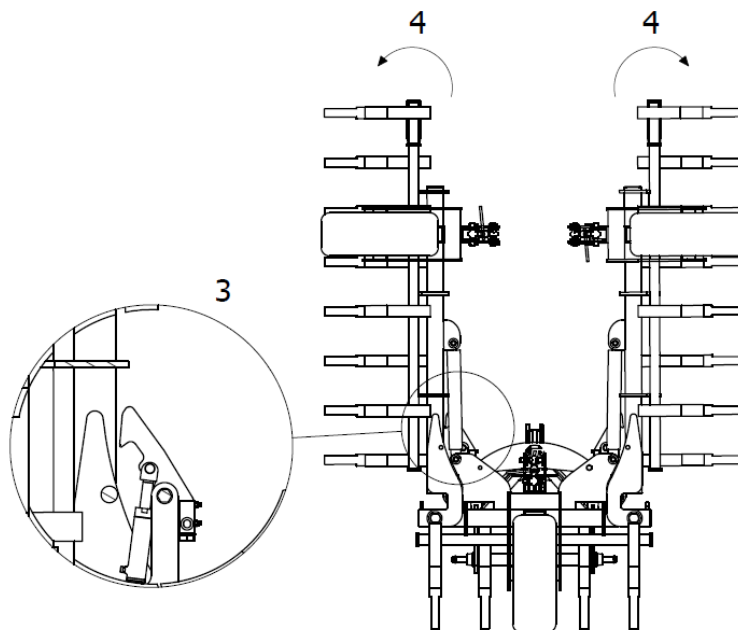

Fig. 5 Implement opening sequence: 3- release the hook of the hydraulic side extension lock mechanism, 4- open the implement side extensions.

- When opening the implement's side extension arms, make sure that the ends of the arms are at the correct height to prevent them from snagging on the ground (Fig. 6).

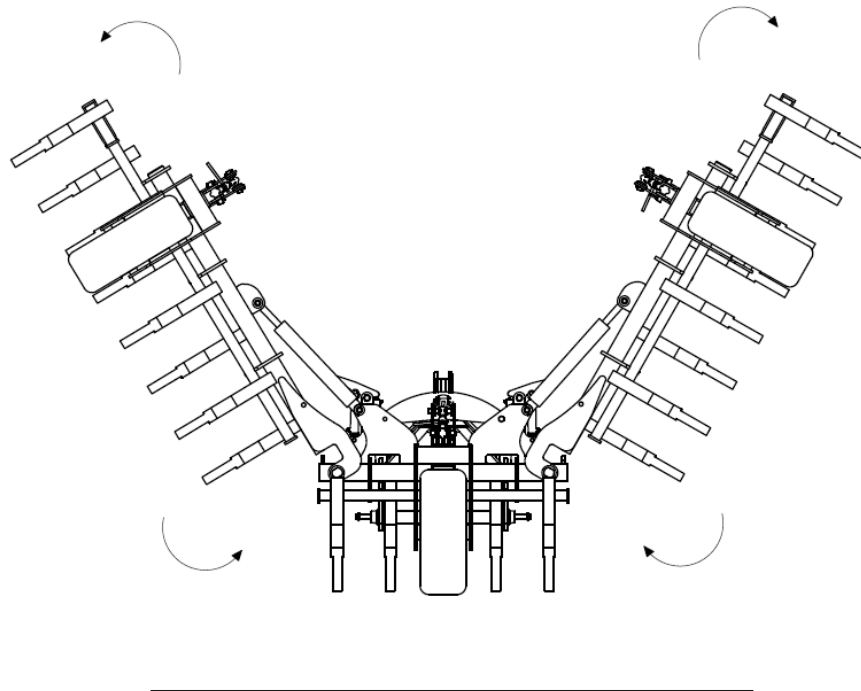

Fig. 6 Implement opening sequence: open the implement paying particular attention to the height of the arm ends from the ground.

- To complete the opening sequence of the implement side extensions, wait until the hydraulic mechanism opens the arms to their end position. Do not interrupt the opening process of the arm side extensions without ensuring that they are fully open (Fig. 7).

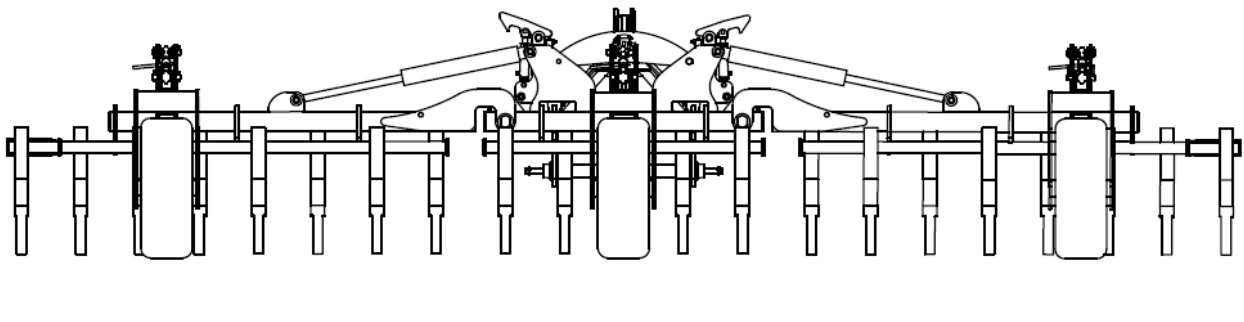

Fig. 7 View of the implement at the completion of the side extension opening sequence. The implement arms are fully open.

4.3.3. FRONT cultivator working depth

The working depth is adjusted with the three-point hitch arms and the position of the support wheels relative to the spring tines. Adjustments are made with turnbuckles on both support wheel assemblies (Fig. 8). Initially, the wheels should be set above the lower edge of the tines at a height that roughly corresponds to the assumed working depth, and this setting should be adjusted in operation after taking into account the recess of the spring tines.

The position (height) of the two support wheels must always be equal in order to ensure even operation over the entire working width of the cultivator. The maximum working depth is 15 cm.

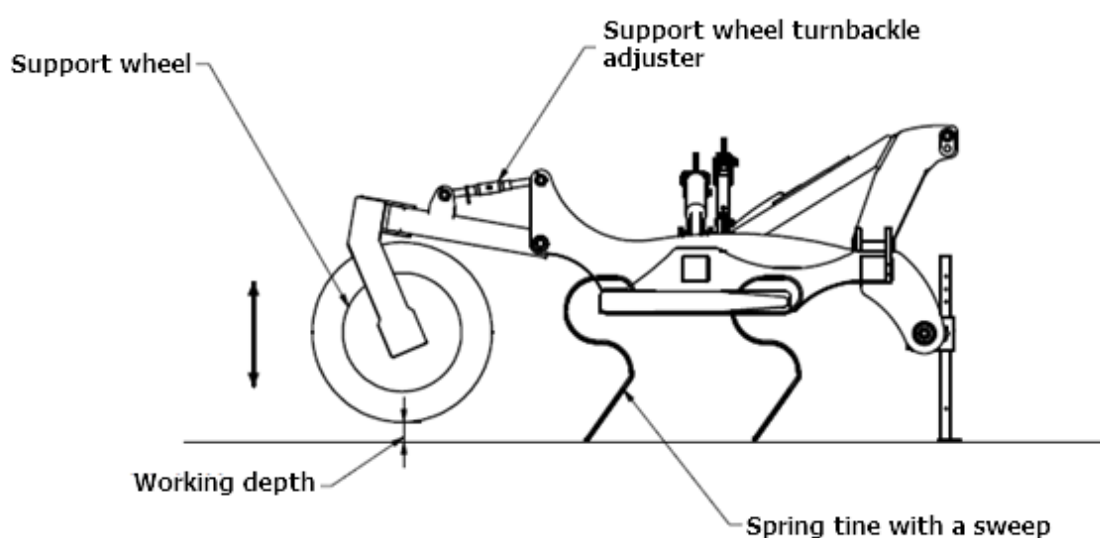

Fig. 8 Working depth adjustment.

4.4. Rules for transporting the cultivator on public roads and lighting the implement

According to the road traffic safety regulations (Regulation of the Minister of Infrastructure of 31 December 2002, Journal of Laws No. 32 of 2002, item 262) - a unit consisting of an agricultural tractor and an agricultural implement hitched with the same must meet the requirements identical to those applying to the tractor itself.



CAUTION! The implement protruding outside the rear side outline of the tractor and obscuring tractor rear lights is a hazard for other vehicles driving on the roads. Be sure to observe the transport instructions specified in chapter 3 "General safety information". Driving on public roads without adequate marking is forbidden.

The implements must be equipped with:

- triangular board for slow vehicles;
- two boards facing front with a white parking light and a white retroreflector;
- two boards facing rear with composite lamp and a red retroreflector. The plates should be painted in diagonal white and red stripes.

After fixing the plates, connect the electrical cables of the light and signalling device to the tractor's electrical socket.

The manufacturer does not supply warning plates as standard equipment for the machine. Warning plates are commercially available.

Always adapt your driving style to the road conditions to avoid accidents and damage to the driving system. Take into account your own skills and traffic intensity, visibility and weather conditions.

Clean the implement from soil residues and check the lights before transporting it. After lifting the machine, check the ground clearance under the lowest working elements, which should be at least 25 cm. The permissible transport speed of the tractor and machine is 15 km/h. It should be 10 km/h in case of poor road surface and 5 km/h on dirt roads. Special care must be taken when passing and overtaking other vehicles, bypassing obstacles and crossing large areas of uneven ground and dirt roads.

4.5. Maintenance and lubrication

- Clean the cultivator from soil after each use and inspect the parts and assemblies. **Otherwise, in the case of the working components being clogged with soil and the additional load occurring due to this, there may be a problem with the folding of the implement.**
- After the first 4 hours of operation, re-tighten all bolts and periodically check them for tightness.
- The ploughshare points can be used until they are almost completely worn out, until the working surface is level with the initial surface of the ploughshare foot. However, it is recommended to replace the points in good time before there is a possibility of wear and tear and damage to the ploughshare foot.
- Lubricate the lubrication points on the hinge pins daily during the machine's service life. Lubricate the bearings of the roller and the levelling discs every 25 operating hours (not applicable to disc maintenance-free bearings - these bearings do not require maintenance or lubrication).
- Use thread adhesive and only genuine screws and nuts when replacing worn parts.
- For screwing the working elements use M12 screws 10.9 and tighten them with 135 Nm torque.
- Replace or refurbish any damaged or worn parts.
- Always remember to tighten the screwed joints properly.

CAUTION! Periodic lubrication guarantees the long service life of the machine.

The long service life and efficiency of a machine depends to a large extent on regular lubrication. Use mineral greases for lubrication. Clean the lubrication points thoroughly before pressing or applying grease.

4.6. Screw tightening torque

Screws, bolts and nuts should be tightened in the machine with the appropriate torque depending on the strength class of the bolt and its thread size and pitch. The corresponding torque values for tightening them are shown in Table 3.

Table 3. Screw, bolt and nut tightening torque

Nuts & bolts torque [Nm]					
Size		Thread pitch	Nuts & bolts strength grade		
			8.8	10.9	12.9
	M4	0,7	3,2	4,5	5,2
	M5	0,8	6	8,4	10
	M6	1,0	11	15	17
	M8	1,3	27	34	40
		1,0	21	30	35
	M10	1,5	46	65	76
		1,3	41	75	67
		1,0	36	50	59
	M12	1,8	79	111	129
		1,3	65	91	107
	M14	2,0	124	174	203
		1,5	104	143	167
	M16	2,0	170	237	277
		1,5	139	196	228
	M18	2,0	258	363	422
		1,5	180	254	296
	M20	2,5	332	469	546
		1,5	229	322	375
	M22	2,5	415	584	682
		1,5	282	397	463
	M24	3,0	576	809	942
		2,0	430	603	706
	M27	3,0	740	1050	1250
		2,0	552	783	933
	M30	3,5	1000	1450	1700
		2,0	745	1080	1270
	M36	4,0	1290	1790	2020
		2,0	960	1340	1500



CAUTION! It is forbidden to work on a damaged machine caused by any event resulting in a broken, or deformed frame, roller or other assembly of the machine!

5. FRONT cultivator maintenance

Daily maintenance

Thoroughly clean the cultivator removing soil and plant residues after each use; inspect the screw, pin and bolt connections and the condition of the operating elements and other parts. When cleaning, remove plant residues and ropes wound at the disc and roller bearing points. Replace any damaged or worn parts. Tighten any loose screw connections and replace damaged cotter pins and pins.

Post-season maintenance

At the end of the working season, clean the cultivator thoroughly and repair the spots of damaged paint coating. The worn working surfaces of the tines, discs, strings and roller rings as well as the threads of the adjusting screws must be washed, dried and protected against corrosion. In addition, perform complete lubrication. It is recommended to store the machine under a roof during the operational break. If this is not possible, check the condition of the protection from time to time and supplement the grease washed away by the rain, if necessary. **The cultivator should be stored in a place which does not pose any hazard to persons or the environment.** When unhitched from the tractor, the implement must be supported on a firm, level surface. Also, the parts that have been disassembled and removed from the implement must be stored securely supported on the ground to prevent uncontrolled movement.

5.1. Hydraulic system maintenance

Maintenance of the hydraulic system consists in visual inspections for leak tightness. Remember to insert pins into quick-fit connectors. In case of leakage from connections of hydraulic hoses, the connector must be tightened. If the oil leakage is not remedied, replace the workpiece or the hose with a new one. If the leakage occurs outside the connector, the leaking hose must be replaced with a new one. Mechanical damage also requires replacement of the subassembly. It is recommended that the hydraulic hoses be replaced every 5 years.

If oil appears on the piston rod of the hydraulic cylinder, check for the nature of the leakage. Check the sealing once the piston rod is fully moved out. Small leakage which results in covering the piston rod with an oil film is acceptable (damaged wiper seal). If the amount of oil is greater or there are oil drops, shut down the unit for the period required to repair the malfunction (damaged sealing).

6. Replacement procedures

Replacement of bearings in the support wheels

Replace the damaged bearings following the steps below:

- place the machine on a horizontal surface,
- unscrew the four bolts securing ball bearings on each side,
- loosen both headless bolts in each bearing to be able to pull the bearings out with the use of a puller,
- loosely place new bearings on the wheels,
- roll the wheels between the bearing plates and bolt the bearings to them. Drive the headless bolts with the use of a thread locking glue,
- if damaged, replace the entire wheel holder.

Replacement of workpieces

Excessively worn workpieces hinder soil penetration by the tools and increase the working resistance. Replace the workpieces on the implement when the it is lowered to the ground with the tractor engine stopped. To ensure that the parts to be replaced are not resting on the ground, robust washers must be placed under the roller. Upon lowering the cultivator, switching off the tractor engine and applying the hand brake, check the stability of the tractor-implement unit. Use only standard screws to fix new parts or workpieces.

If the components of the machine are disassembled several times, it is necessary to inspect and replace (if required) connecting components such as bolts, washers or nuts, excessive wear of which can lead to uncontrolled loosening of the connected components, and consequent damage to the same.

Work with extremely worn work tools can cause damage to other workpieces of the machine. Tools should be replaced when their wear and tear exceeds the limits allowed by the manual. Otherwise damage may occur, for which the manufacturer **SHALL NOT BE HELD RESPONSIBLE!**

Replacement of cylinders

A malfunctioning cylinder (leakage, etc.) must be replaced. Dismount it to have it inspected by a specialised company. Cylinder replacement must be performed by a specialised company. Cylinder replacement must be performed when the implement is unfolded. Connect the cylinder to the system and with one side mounted repeat the operating cycle several times until the cylinder is completely filled with oil. Otherwise, the section being lowered may suddenly fall down.



CAUTION! During repairs and maintenance, the implement must be lowered on the ground and be resting on supports ensuring full stability. The tractor engine must be stopped. During repairs and maintenance, use proper spanners and safety gloves.

7. FRONT cultivator storage

After the end of the work season, check the parts and assemblies. If any part is found damaged or considerably worn, replace it with a new one. Areas of damaged paint must be cleaned out of dirt and rust. Apply anti-corrosive paint, and then apply a topcoat paint. Protect the working surfaces of the cultivator tines and the roller from corrosion. It is recommended to store the machine under a roof during the operational break. However, if this is not possible, check the condition of the protection from time to time and supplement the grease washed away by the rain, if necessary.

Clean the piston rods of the hydraulic cylinders during winter and when the machine is not in use for a long period of time, and protect them from corrosion with vaseline or acid-free grease.

When unhitched from the tractor, the implement must be supported on a firm, level surface with a stable balance. All work units should rest on the ground. Lower the implement gently so that it does not come into contact with hard surfaces. When lowering the implement, unhitch the suspension system and drive away the tractor. Also, the parts that have been disassembled and removed from the implement must be stored securely supported on the ground to prevent uncontrolled movement. It is advisable to store the implement on a hardened firm surface in roofed areas, inaccessible to unauthorised persons, bystanders and animals.



Store the machine firmly supported on a hardened firm surface so that no injury is caused to persons or animals.



CAUTION Disconnect the unit from the tractor before performing any disassembly activities.

8. Disassembly and withdrawal from service and scrapping

When operated in accordance with the guidelines in the instruction manual, the implement will have a long service life, however worn or damaged parts must be replaced. In the event of emergency damage (cracks or deformation of the frames) impairing the quality of the machine operation and posing a risk to its further operation, the machine must be withdrawn from service.

Disassembly of the implement should be carried out by persons who are familiar with its design and construction. These operations must be performed when the implement is placed on a level, firm and stable surface. Sequence of activities:

- Disconnect the tubular roller clamp from the arms. Unscrew the bearing retaining screws and roll the roller sideways.
- Disconnect the roller arms from the frame.
- Remove the drawbar arms connecting the drawbar to the central frame.
- Dismount the drawbar.
- Place the cultivator frame on stable stands. For implements with folding side arms, additional stands must be prepared.
- Dismantle the working elements of the implement.
- Disconnect the side arm supports from the central frame.
- Perform dismantling operations of the hydraulic system components wearing gloves and safety glasses. There is a blockage of oil return flow in the hydraulic system, which means that there is high pressure in the hydraulic lines. Wrap the connectors in oil fabric before unscrewing the hoses. Drain the old oil in a container (bucket).

Scrapping:

- The unit should be withdrawn from service and scrapped after complete disassembly and verification of the machine components.
- During disassembly, sort the parts by their material.
- Waste ferrous metal parts should be grouped together at the collection points for ferrous metals.
- **Dispose of worked oil, rubber pads and hoses as waste and hand them over to the disposal companies.**

9. FRONT cultivator - spare parts

In order to search, find prices and order original spare parts visit our website at www.mandam.com.pl, "parts" tab.

There you can find catalogues and spare part sheets in PDF format, containing current part drawings and diagrams for each machine or implement, together with part numbers and prices.

Purchase orders for parts can be placed or enquiries related to the same can be sent directly from this website (tab: "contact/order"), or sent to the following e-mail address: czesci@mandam.com.pl

A purchase order should contain part numbers and quantities, as well as details of the ordering party/payer together with a contact phone number.

The parts are sent directly to the specified address on the COD basis.

If in doubt, please contact Mandam Spare Parts Department at: +48 32-232-2660 extension 39 or 45 or at + 48 668-66-22-89 (mobile).

Original MANDAM spare parts are also available from all authorised MANDAM distributors.