

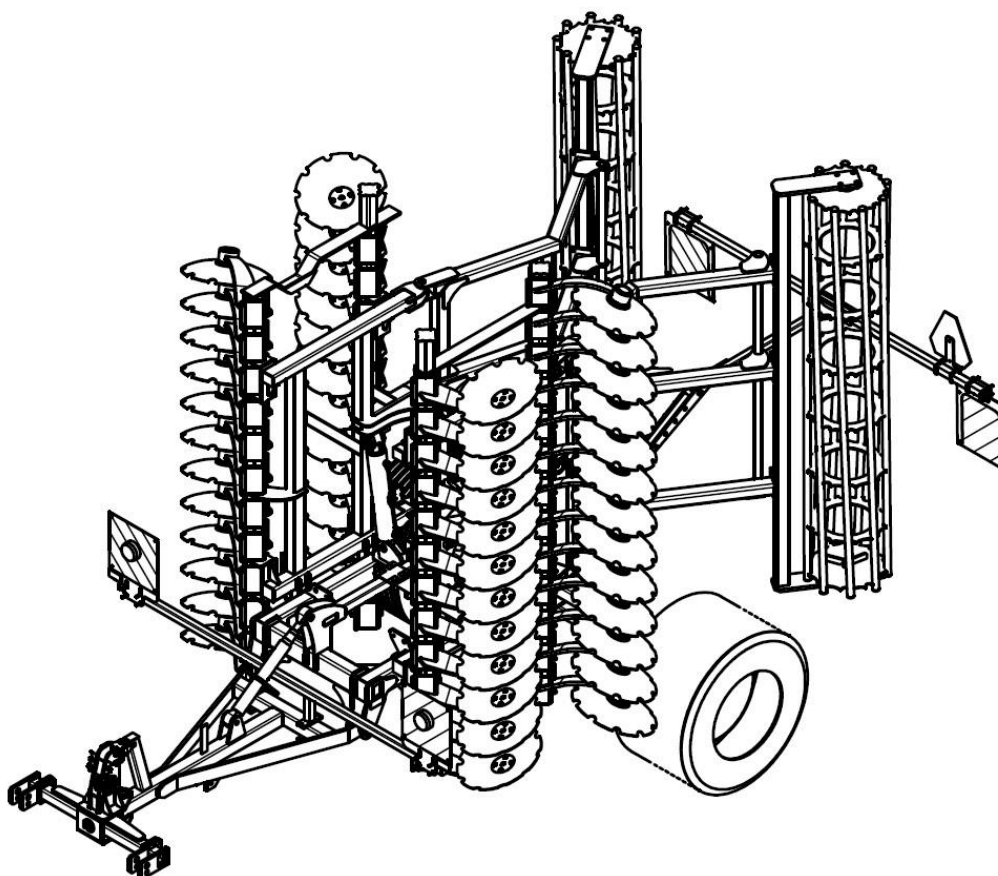

MANDAM Sp. z o.o.
ul. Toruńska 14 44-100 Gliwice, Poland
e-mail: mandam@mandam.com.pl
Tel.: 032 232 26 60 Fax: 032 232 58 85
NIP (VAT no.): 648 000 16 74 REGON (Registration no.): P - 008173131

INSTRUCTION MANUAL

HYDRAULIC DISC HARROW with BTH-D drawbar



Issue II
Gliwice 2022



DECLARATION OF CONFORMITY



FOR A MACHINE

In accordance with the Ordinance of the Minister of the Economy dated 21 October 2008 (Journal of Laws No. 199, item 1228)
and the Directive of the European Union no. 2006/42/EC of 17 May 2006

MANDAM Sp. z o.o.

ul. Toruńska 14

44-100 Gliwice

hereby declares at its sole responsibility that the following machine:

<p>BTH disc harrow with BTH-D drawbar</p> <p>type/model:</p> <p>year of manufacture:</p> <p>serial number:</p> <p>VIN:</p>

under this declaration, complies with:

the **Ordinance** of the Ministry of Economy of 21 October 2008 on fundamental requirements for machinery (Journal of Laws No. 199, item 1228)
and the **Directive** of the European Union 2006/42/EC of 17 May 2006.

The persons responsible for the technical documentation for the machine: Jarosław Kudlek, Łukasz

Jakus

ul. Toruńska 14, 44-100 Gliwice, Poland

For assessment of compliance the following standards have been applied:

- PN-EN ISO 13857:2010
- PN-EN ISO 4254-1:2016-02
- PN-EN ISO 12100-1:2005/A1:2012
- PN-EN ISO 12100-2:2005/A1:2012
- PN-EN 982+A1:2008

This EC Declaration of Conformity shall be cancelled
if the machine is modified or redesigned without consent of the manufacturer.

Prezes Zarządu
Dyrektor

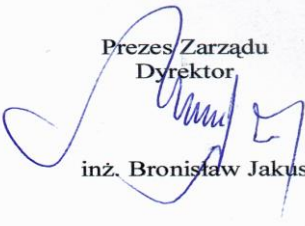

inż. Bronisław Jakus

Vice Prezes Zarządu
Dyrektor ds. Techniczno-Organizacyjnych

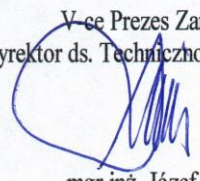

mgr inż. Józef Seidel

.....
Place and date of issue

.....
First and last name, position held
and signature of the person authorized

1.	Introduction	4
1.1.	<i>Safety symbols and inscriptions</i>	6
2	General information	8
2.1.	<i>Design of the BTH disc harrow with BTH-D drawbar</i>	8
2.2.	<i>Intended use of the BTH disc harrow with BTH-D draw</i>	9
3	General safety information	10
3.1.	<i>Proper hitching and unhitching of the harrow with/from the tractor</i>	11
3.2.	<i>Tyres</i>	11
3.3.	<i>Hydraulic and pneumatic systems</i>	11
3.4.	<i>Brake system</i>	13
3.4.1	Dual-circuit hydraulic brake	13
3.4.2	Automatic brake valve with spring brake – 206613	13
3.5.	<i>Hydraulic system quick couplings</i>	20
3.6.	<i>Transport safety on public roads</i>	21
3.7.	<i>Residual risk description</i>	22
3.8.	<i>Residual risk assessment</i>	22
4	Information on operation and use	22
4.1.	<i>Preparation of the disc harrow</i>	24
4.2.	<i>Hitching the harrow with the tractor</i>	25
4.3.	<i>Hitching the sower with the disc harrow</i>	26
4.4.	<i>Operation and adjustment</i>	26
4.4.1	Automatic locking of the machine side extensions	26
4.4.2	Implement opening sequence	27
4.4.3	Working depth of the BTH disc harrow with BTH-D drawbar	29
4.5.	<i>Rules for transporting the harrow on public roads and lighting the implement</i>	32
4.6.	<i>Maintenance and lubrication</i>	34
4.7.	<i>Screw tightening torque</i>	35
5	Maintenance of the BTH disc harrow with BTH-D drawbar	36
6	Replacement procedures	38
7	Storage of the disc harrow	39
8	Disassembly and withdrawal from service and scrapping	40
9	Spare parts for the BTH disc harrow with BTH-D drawbar	40

1. Introduction

Congratulations on your purchase of the BTH disc harrow with BTH-D drawbar. This instruction manual contains the information on hazards that may occur during operation, work with the device, technical data and the most important guidelines and recommendations to be known and applied to ensure a proper operation. Keep this manual for future reference. Should you have any problems with understanding any statement in the instruction manual, please contact the manufacturer.

The following mark indicates the guidelines that are important due to safety reasons:



Machine identification

Identification data of the BTH disc harrow, including basic information on the manufacturer and the machine and CE marking, can be found on the rating plates placed on the load-bearing frame:

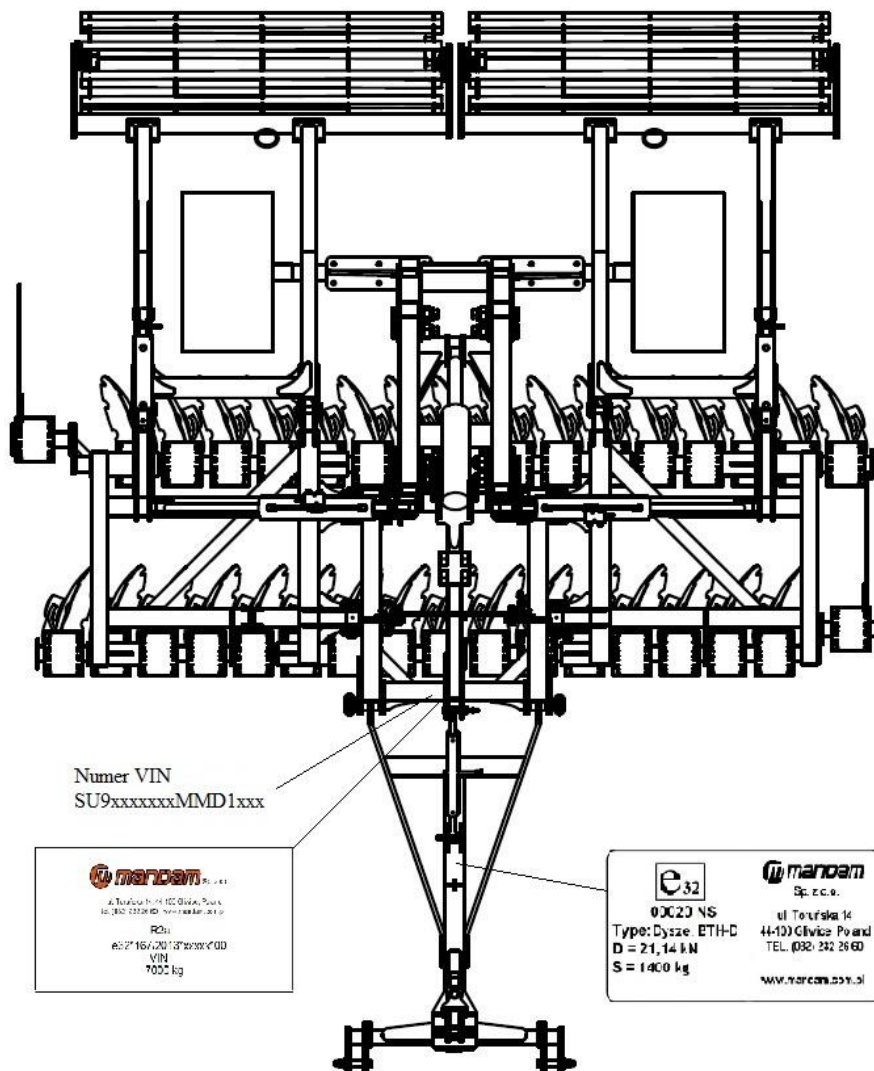

Fig. 1 View of the harrow with location of markings.

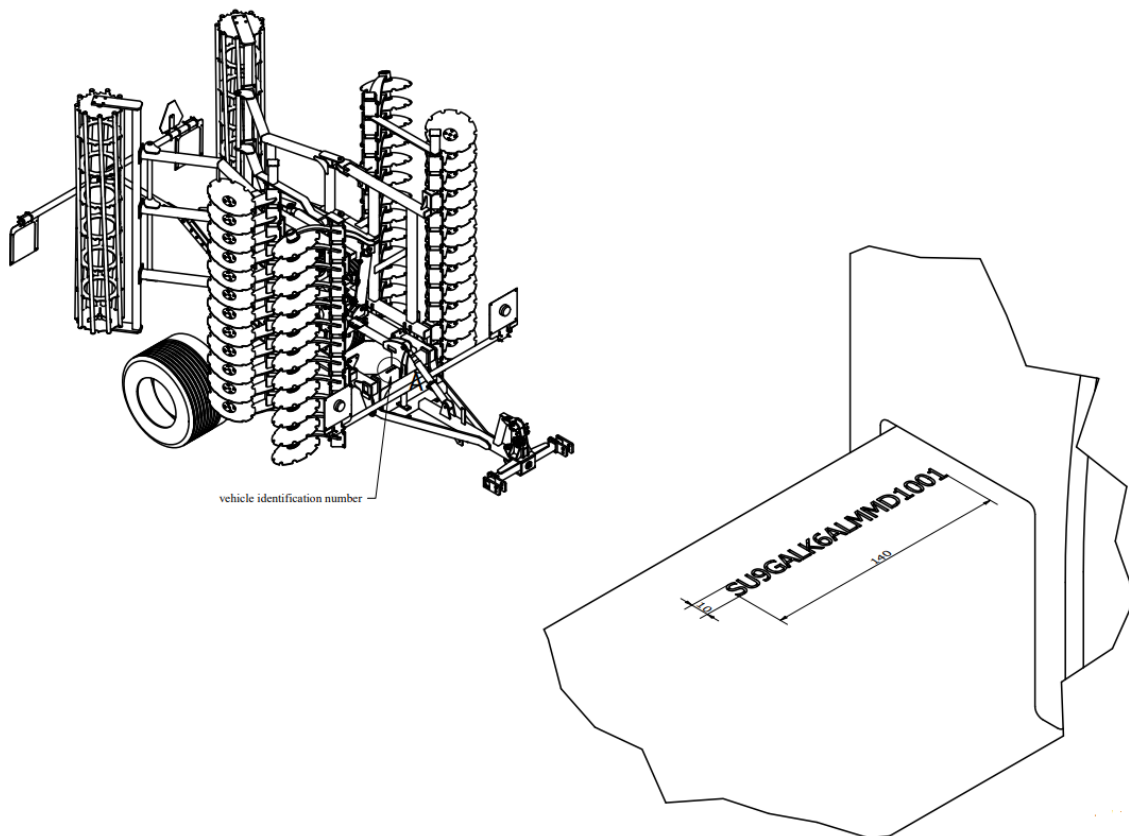

Fig. 2 Location of VIN placed on the machine.

 00020 NS Type: Dyszel BTH-D D = 21,14 kN S = 1400 kg	 Sp. z o.o. ul. Toruńska 14 44-100 Gliwice, Poland TEL. (032) 232 26 60 www.mandam.com.pl
--	--

 R2a e32*167/2013*xxxxx*00 SU9GALK5HMMMD1001 5300 kg
--

Fig. 3 Rating plate of the BTH disc harrow.

The warranty for the harrow is valid for 12 months from the date of sale.

The warranty card constitutes an integral part of the machine.

Whenever you request any information on spare parts, provide the serial number.

For more information on spare parts,

- please visit our website at: <http://mandam.com.pl/parts/>
- call us at +48 668 662 289
- e-mail us at: czeski@mandam.com.pl

1.1. Safety symbols and inscriptions







CAUTION! Special care must be taken when using the implement in case of areas marked with special information and warning signs (yellow stickers).

The following symbols and inscriptions can be found on the implement. Secure the symbols, signs and inscriptions against loss and make sure they are legible at all times. If lost and illegible, replace the symbols, signs and inscriptions with new ones.

Table 1. Information and warning signs.

<i>Safety sign</i>	<i>Meaning of the safety sign</i>	<i>Location on the implement</i>
	Read the instruction manual prior to operating the implement.	Frame adjacent to the mounting place of the upper fastener
	Danger of toe or foot crush	Frame adjacent to the mounting place of the upper fastener

Safety sign	Meaning of the safety sign	Location on the implement
	<p>Keep clear from lift bars while controlling the lift</p>	<p>Frame adjacent to the mounting place of the upper fastener</p>
	<p>Keep clear from foldable and moving parts of the implement</p>	<p>Front part of the central frame adjacent to side frames</p>
	<p>Do not reach into the crushing zone if the elements can move</p>	<p>Central frame adjacent to side frames</p>
	<p>Pressurized fluid - hazard of bodily injury</p>	<p>Cylinders</p>
	<p>Fixing point for transport belts</p>	<p>Upper part of the drawbar (upper fastener bolt) Rear part of the frame:</p> <ul style="list-style-type: none"> • rigid frame (adjacent to the roller depth adjustment) • foldable frame (adjacent to the cylinder bolt on the central frame)

2 General information

2.1. Design of the BTH disc harrow with BTH-D drawbar

The harrows are available in the following widths: 4.0 m, 5.0 m, 6.0 m, and 8.0 m.

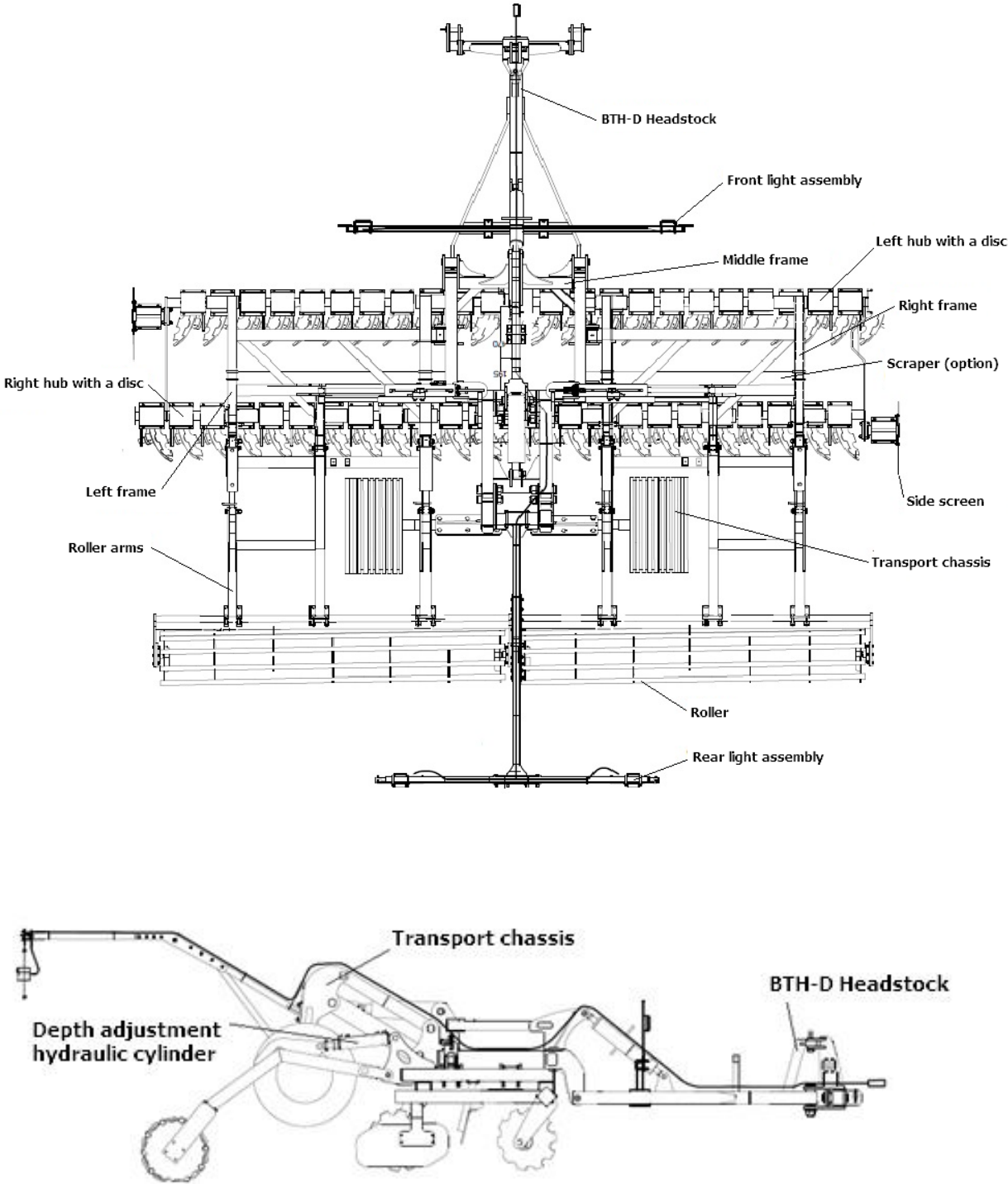

Fig. 2 BTH disc harrow with BTH-D drawbar.

Table 2. BTH disc harrow types.

Harrow type	Working width [m]	Tined disc diameter [mm]	Number of discs [pcs]	Min. tractor power [hp]	Wheel size
GAL-K 4.0H	4	560	32	150	480/45-17"
GAL-K HD 4.0H		610			
GAL-K 5.0H	5	560	40	180	480/45-17"
GAL-K HD 5.0H		610			
GAL-K 6.0H	6	560	48	200	480/45-17"
GAL-K HD 6.0H		610			
TAL-K 4.0H	4	560	32	150	620/40-22.5"
TAL-K 5.0H	5	560	40	180	620/40-22.5"
TAL-K 6.0H	6	560	48	200	620/40-22.5"
TAL-K 8.0H	8	560	64	220	620/40-22.5"
SAL-K 6.0H	6	610	48	220	620/40-22.5"

2.2. Intended use of the BTH disc harrow with BTH-D draw

The disc harrow is designed for post-harvesting (with crushed straw) and pre-sowing cultivation in both plough and ploughless technology. The implement can also be used for mixing aftercrop or uncultivated land with high self-sown plants with soil.

The working elements are tined discs with the diameter of Ø610 mm and Ø560 mm in two shifted rows mounted on maintenance-free bearings. Equipping each disc with its own bearing allows for an optimum inclination of the disc in relation to the direction of travel and the ground. This allows the stubble to be accurately cut and ensures that the post-harvesting crop residues are evenly mixed and ground. As a result, evaporation of the soil is interrupted, plant residues decompose more quickly and the intensity of phenolic compounds, which have a negative impact on the development of successive crops, is reduced. Disc tines help to penetrate the ground. Rollers at the rear of the implement compact the soil, resulting in faster germination of weeds and self-sown plants. The use of a disc harrow before sowing ensures a precise mixing of fertilisers with the soil, an even surface and an appropriate soil structure.

The harrow can also be equipped with a hydropack for coupling with a sower. BTH implements with a BTH-D drawbar are (optionally) equipped with their own driving system with a braked axle. The pneumatic system is used for this purpose.



CAUTION! MANDAM grants a 5-year warranty on maintenance-free hubs subject to the following conditions:

- the principle is observed of the working disc replacement in case of their wear which may not exceed the diameter of 490 mm for Ø560 mm discs, and 550 mm for Ø610 mm discs,
- original MANDAM discs are used,
- the permissible working depth, which is 12 cm for Ø560 mm discs and 15 cm for Ø610 mm discs, is not exceeded,
- the principle is observed of no turning manoeuvre of the harrow when it is in the working position (working discs recessed in the soil).



CAUTION! The disc harrow is designed for agricultural use only. Using the implement for tasks that differ from the intended use shall be regarded as misuse, resulting in loss of warranty. Failure to follow the guidelines included in this instruction manual shall be regarded as misuse.



CAUTION! The manufacturer shall not be liable for any damage arising out of misuse.

3 General safety information

The disc harrow can be started, operated and repaired only by persons familiar with its operation and with the operation of the attached tractor as well as knowing the rules of safe operation and maintenance of the implement.

The manufacturer shall not be liable for any unauthorised alternation of the harrow. Only genuine MANDAM spare parts shall be used during the warranty period.

The disc harrow must be operated with all precautionary measures and due care, in particular:

- before every start-up check the disc harrow and the tractor, make sure that their conditions guarantee safety of traffic and operation;
- minors, disabled or intoxicated persons (under the influence of alcohol or drugs) must not operate the machine,
- during operation and maintenance wear working clothes, footwear and gloves,
- do not exceed the maximum axle loads and transport dimensions,
- use only original cotter pins and pins,
- do not approach the disc harrow while it is being lifted or lowered,
- do not stay between the disc harrow and the tractor when the engine is running,
- drive away with the implement, lift and lower it slowly and smoothly, without jerking, making sure no outsiders are in the area,
- do not reverse and make U-turns when the implement is lowered to the working position,
- when making U-turns do not use independent tractor brakes;
- during the operation and travel do not stand on the implement and do not put additional loads onto it;
- while making U-turns, pay due caution if anyone is in the vicinity,
- never use the disc harrow on slopes with the inclination exceeding 12° ,
- any repairs, lubrication or cleaning of working components may be performed as long as the engine is not running and the implement is lowered and unfolded,
- there is a hazard of head injury when you perform maintenance or replacement of parts in or under the implement without adequate protection - wear a hardhat,
- during a break in the work, always lower the implement to the ground and stop the tractor engine,
- the harrow with the working width exceeding 3.00 m is equipped with an automatic locking device that blocks the side extensions from uncontrolled opening during standstill and road travel,
- driving and parking the implement on an unstable slope may cause soil slipping,
- store the implement in a manner preventing injury to people and animals.

3.1. Proper hitching and unhitching of the harrow with/from the tractor

- Hitch the implement with the tractor according to the recommendations, use pins and protect the suspension pins with cotter pins.
- When hitching the disc harrow, do not stay between the tractor and the attached implement.
- The tractor used together with the disc harrow must be fully functional and in good working order. It is forbidden to couple the machine to any tractor with a malfunctioning pneumatic system (if the machine has a braked axle) and hydraulic system.
- Remember to observe the following: balance of the tractor and the suspended implement, tractor steerability and braking performance - the front axle load must not drop below 20% of the total tractor load - a kit of front weights;
- When in resting position and disconnected from the tractor, the machine must be stable all the time.
- Place the support leg on a stable ground. Do not use pads under the leg as this may cause instability.

3.2. Tyres

- Tyre pressure cannot exceed the value recommended by the manufacturer. Transporting the implement when the pressure is too low is prohibited. This may cause damage to the implement or an accident when travelling too fast and on very uneven surfaces.
- Considerably damaged tyres (particularly the tyre profile) must be replaced immediately.
- Protect the implement from rolling away when replacing the tyres.
- The repair works on wheels or tyres must be performed by persons trained and authorised for this purpose. Such works must be performed with properly selected tools.

Following every assembly of wheels, check the tightening of nuts after travelling the distance of 50 km.

3.3. Hydraulic and pneumatic systems

The hydraulic and pneumatic systems are pressurised. Take all precautionary measures, in particular:

- do not connect and disconnect hydraulic hoses when the tractor hydraulic system is pressurised (hydraulics set to neutral),
- regularly check the hydraulic and pneumatic connections and hoses;
- do not use the implement until the hydraulic or pneumatic system is repaired.

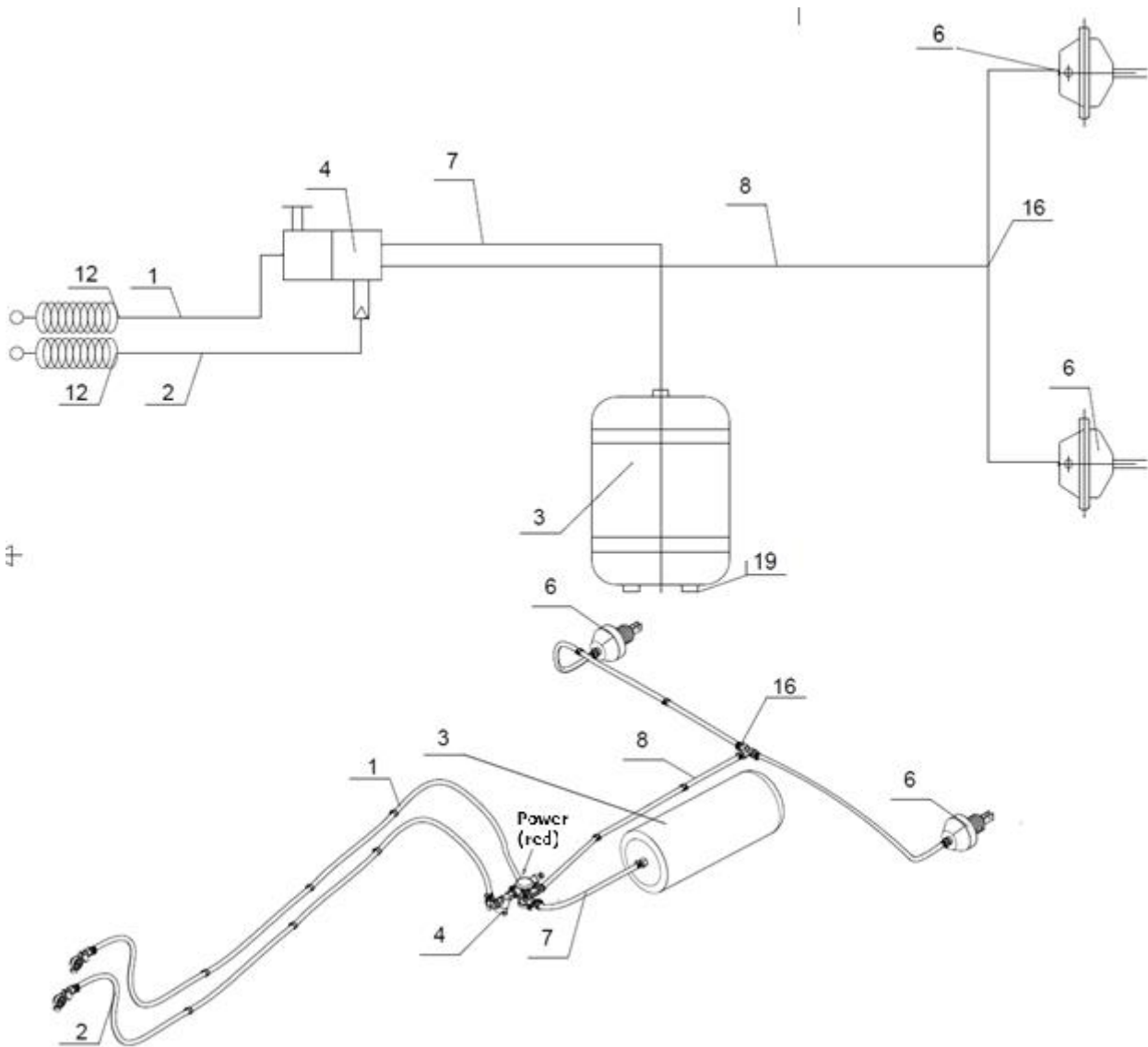

Fig. 3 Pneumatic diagram of BTH harrow with BTH-D drawbar: 1 - spiral wire connector (red), 2 - spiral wire connector (yellow), 3 - 40L air tank, 4 - agricultural trailer control valve, 6 - 24" diaphragm actuator, 7-8 - rubber airline, 12 - adapter, 16 - M22 tee, 19 - tank plug.

3.4. Brake system

3.4.1 Dual-circuit hydraulic brake

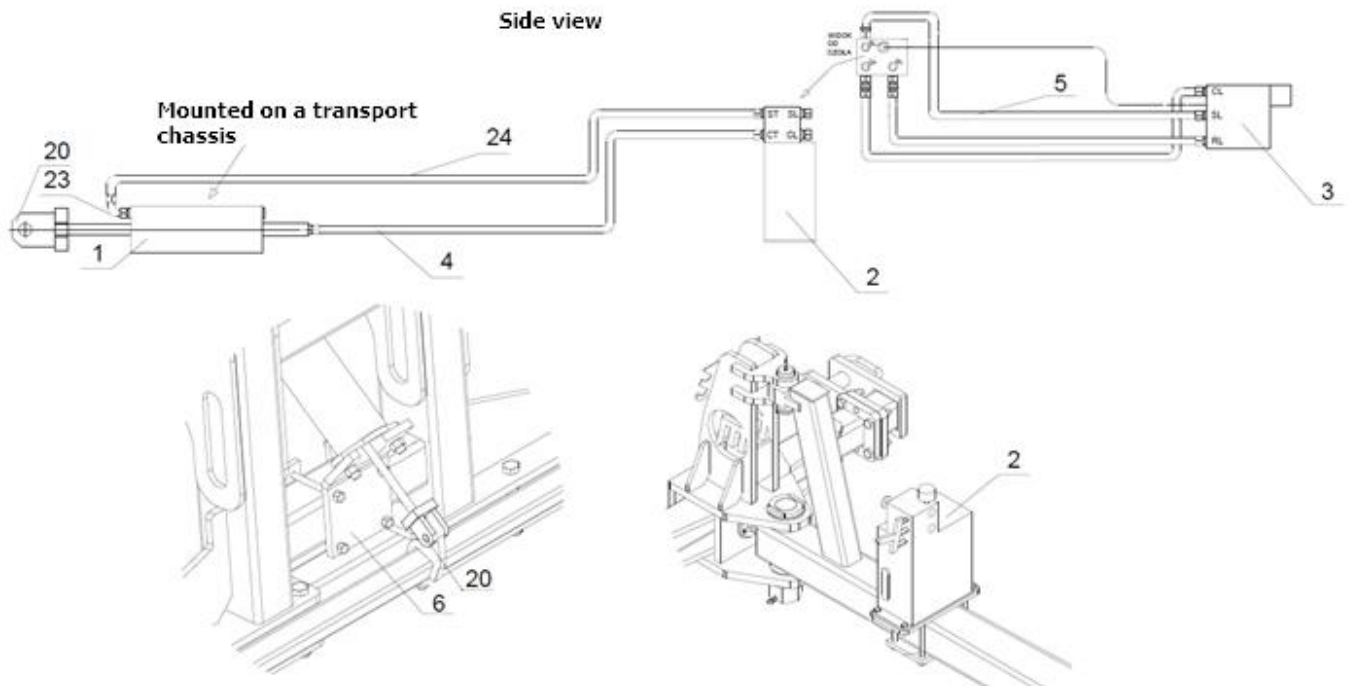

Fig. 4 Diagram of the dual-circuit hydraulic brake with key working components of the BTH harrow with the BTH-D drawbar: 1 - combination brake cylinder, 2 - valve with pump tank, 3 - DLC- dual-line quick coupling with cable, 4-5 - hydraulic line, 6 - hydraulic cylinder mounting plate, 20 - bar handle, 23 - elbow connector, 24 - hydraulic line.

3.4.2 Automatic brake valve with spring brake - 206613

The SAFIM valve on the machine is designed to manage the service and emergency braking functions of the dual-circuit hydraulic braking system. If the trailer is disconnected from the tractor, the automatic brake valve engages the emergency braking function. This function is achieved by using the energy previously stored on the compressed spring of the SAHR actuators which become active when the oil of the spring brake section is discharged into the tank.

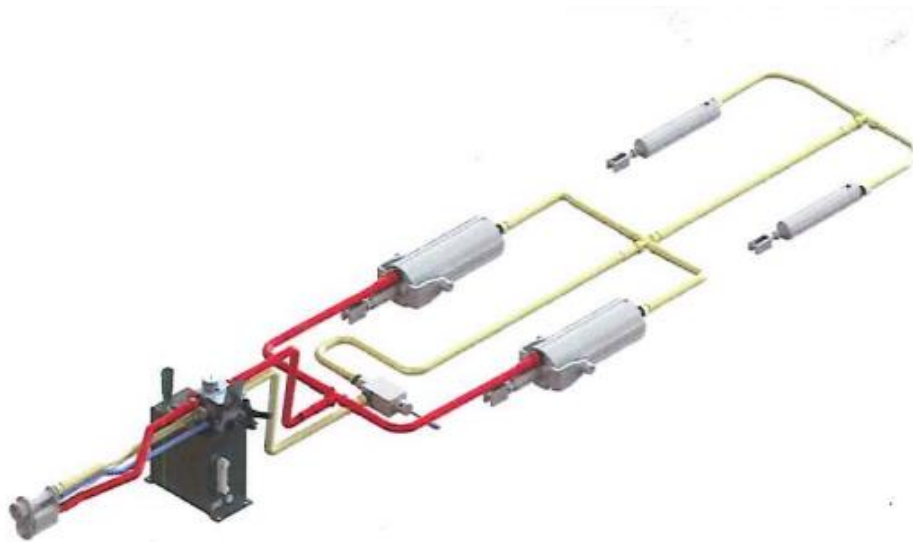

Fig. 5 An overview view of the dual-line hydraulic braking system.

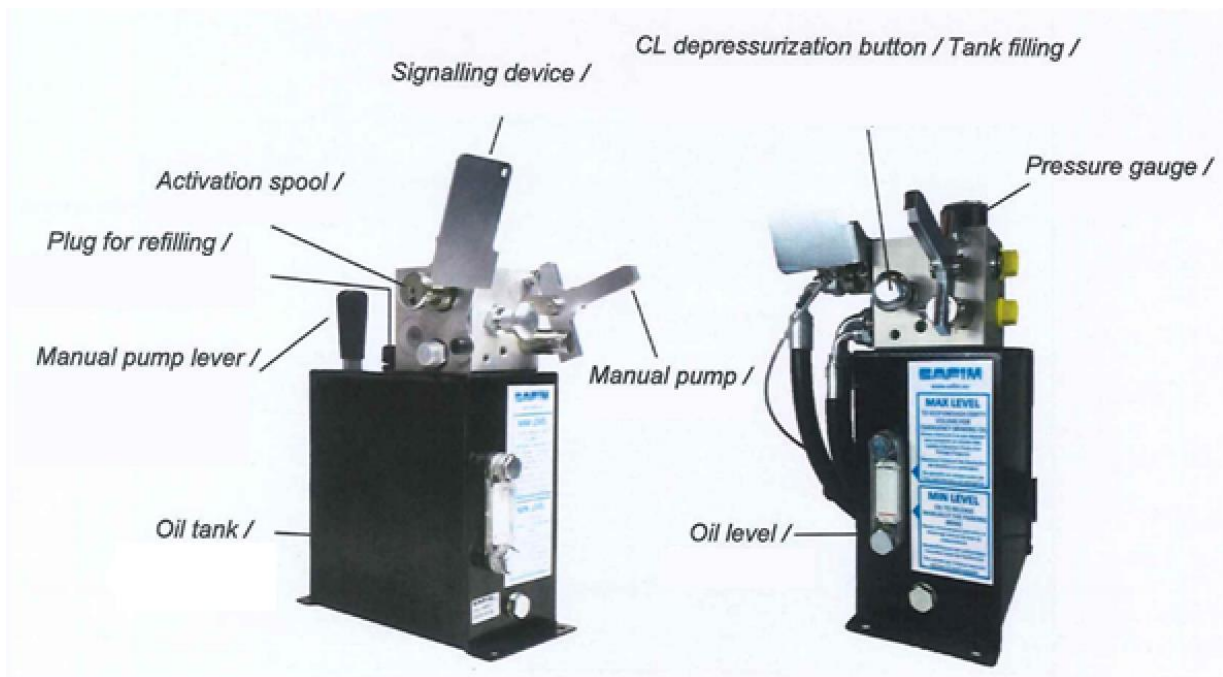

Fig. 6 Valve with marked components.

Figures 7 and 8 show the corresponding valve plans, along with the designations of the most important wires and connectors, where they denote sequentially:

- CL - control line (from the coupling joint),
- SL - secondary line (from the coupling joint),
- RL - return line (from the coupling joint),

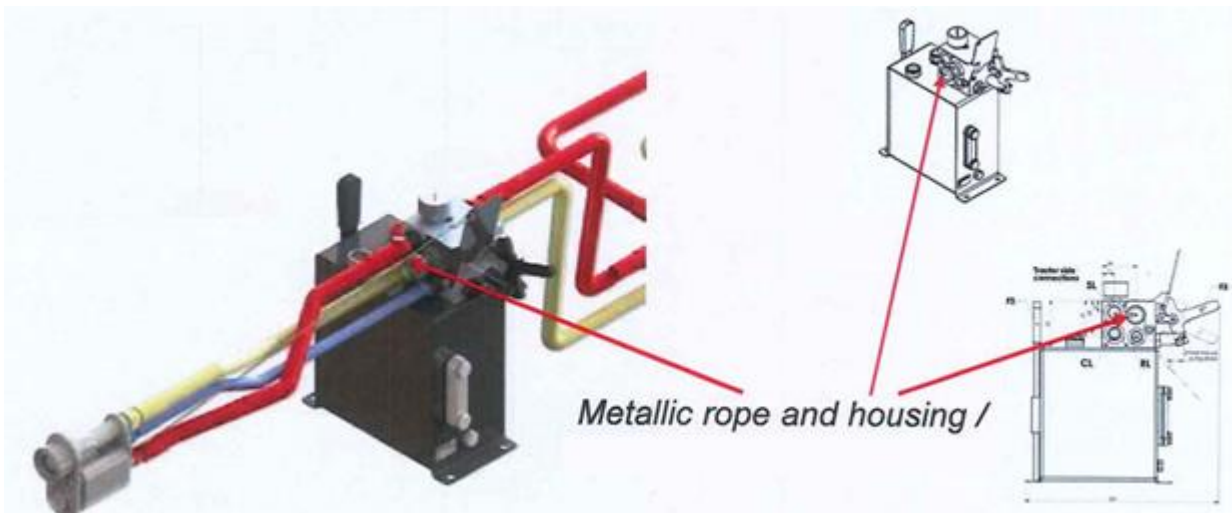

Fig. 9 Marking the connection point of the metal rope to its dedicated housing.

If the braking system includes an automatic load sensing valve of type 206104/xx, connect the SL-A port of the automatic brake valve to the SL port of the load sensing valve.

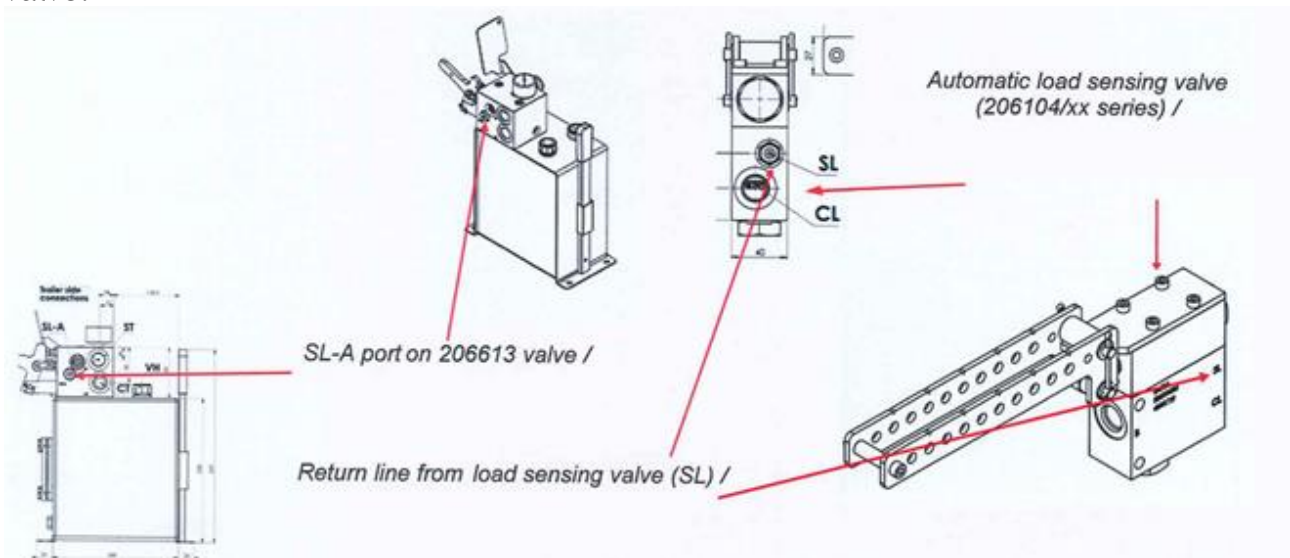

Fig. 10 Marking the place of connection when using automatic load sensing valve type 206104/xx.

The brake valve has several modes of operation. All modes are listed below, along with their descriptions:

Mode 1 - Travel mode:

- Dual-line connector: connection to tractor
- Tractor engine: on
- Parking brake: released

The activation spool automatically returns to the travel mode position when the pressure in the secondary line (SL) increases to its normal value.

The valve's normal function mode is engaged whenever the operator connects the dual-line connector, turns on the tractor engine and releases the parking brake.

The device provides all standard trailer braking functions when the driver brakes. If the trailer is disconnected from the tractor, the automatic brake valve engages the automatic emergency braking function.

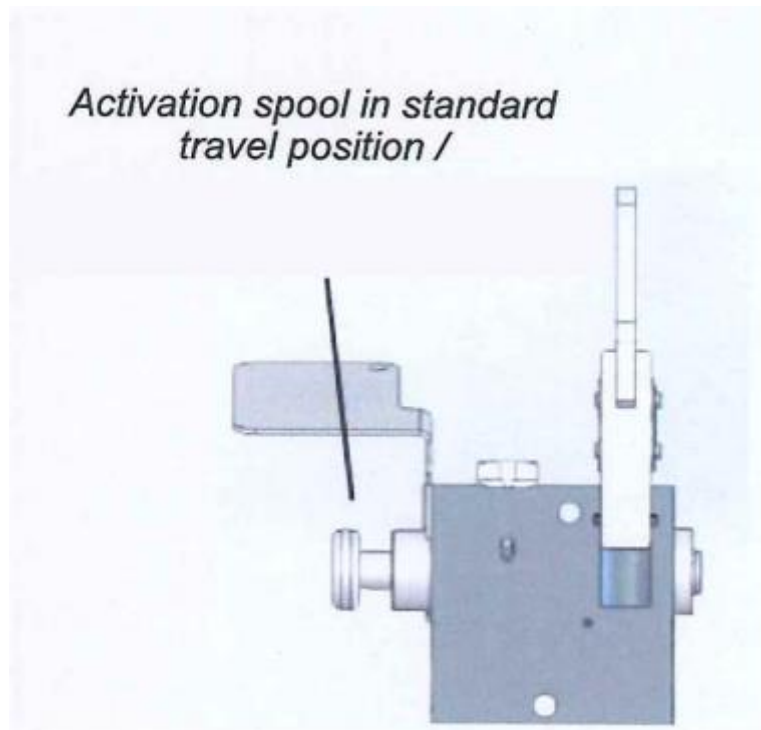

Fig. 11 Standard position of the activation spool in the travel position.

Mode 2 - Emergency mode:

When the trailer is disconnected from the tractor, an automatic brake valve connects the spring brake section of the SAHR cylinders to the tank. The oil holding the springs under tension is discharged into the tank, the spring action activates the emergency brake function.

The automatic emergency brake function is activated even if the pressure in the secondary line (SL) drops while the DLC is still connected to the tractor. The activation spool remains in its normal function position when the automatic brake function is activated.

Mode 2a - Parking mode:

In a spring brake trailer braking system, the application of the automatic emergency braking function overlaps with that of the parking brake, since spring brakes generate both functions. Therefore, disconnecting the DLC connector ensures that the vehicle is properly parked.

If the operator disconnects the double-line connector from the tractor, it is recommended to connect it to the dummy connection of the valve housing to avoid contamination.

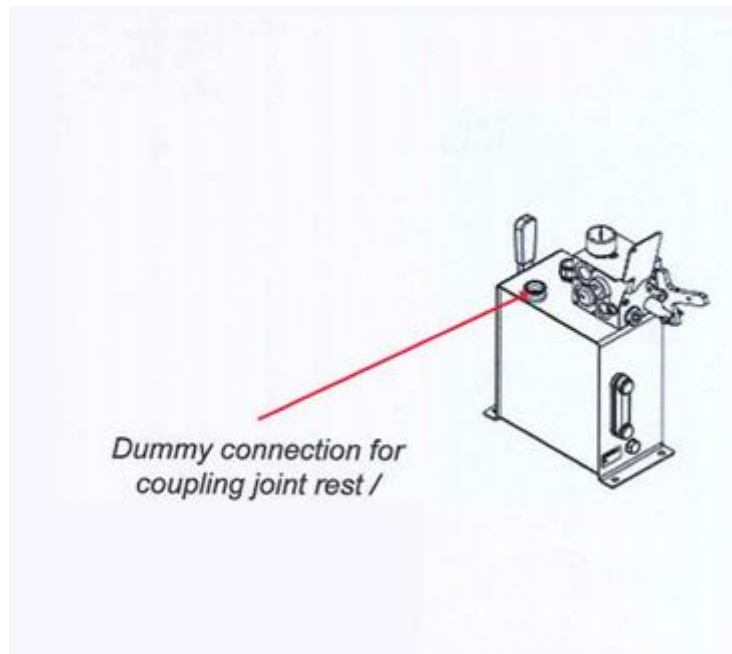

Fig. 12 Port of dummy connection of the remaining coupling joints.

Mode 3 - Removal of the automatic brake function:

To remove the automatic brake function (if towing a trailer by a non-double-line tractor or other type of vehicle):

- Press the activation spool (as in the image on the right) until it is fully extended. The signalling device will move downward generating the activation of manual mode operation;
- Pump oil from the tank into the spring brakes using a manual pump. The auto/parking brake function will be disabled.

NOTE: the brakes will be released when the pressure in the SL toward the spring section of the SAHR actuators is more than 15 bar. When pumping, check the pressure gauge to ensure that it indicates the correct pressure not exceeding 35 bar.

NOTE: whenever the activation spool is in “manual operation/functioning mode”, automatic activation of the parking brake is not ensured. If the vehicle needs to park again, check that the activation spool is in the “standard travel position”.

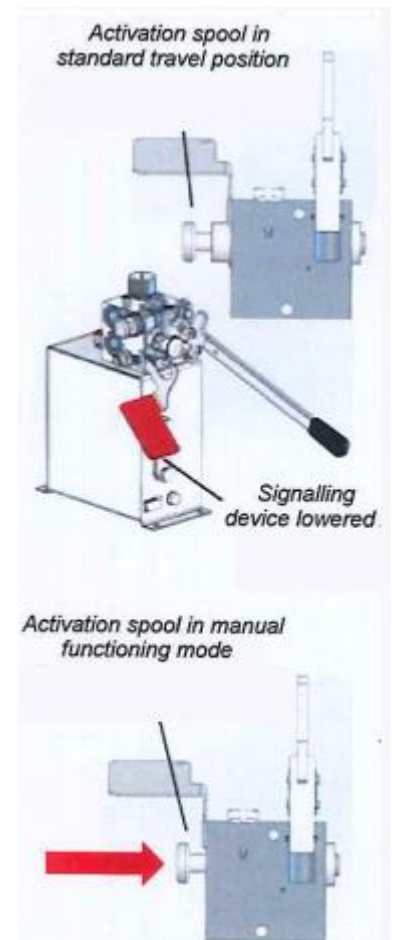

Mode 4 - Reconnecting to the tractor:

The activation spool automatically returns to its normal function position whenever the

pressure in the secondary line (SL) increases to its normal value.

The valve's normal function mode is engaged each time the operator connects the dual-line connector, turns on the tractor engine and releases the parking brake. In this situation, all emergency functions are switched on.

Place the signalling device back to its travel position before turning on the tractor engine and before releasing the tractor's parking brake. If the spool is already in the travel position, it will be impossible to reset the signalling device.

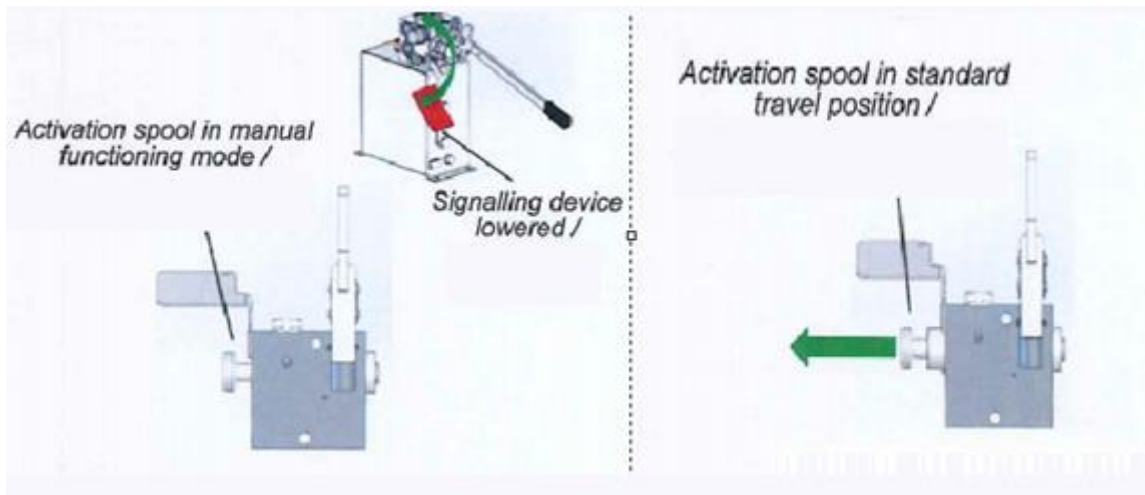

Fig. 13 Positions of the activation spool in the manual functioning position and the standard travel position.

Two alternative procedures are allowed for filling the installation's oil tank after installation. To this end:

- Unscrew the oil plug from the top and fill the tank with the correct amount of oil*;
- Press the “**depressurisation/tank filling**” button from the front side of the valve and, keeping it in the same position, slightly depress the tractor's brake pedal (this procedure requires two operators, one to operate the tractor and the other to operate the valve). The oil coming from the tractor through the control line (CL) will be redirected to the tank. When the oil level is correct, release the “**depressurisation/tank filling**” button.

*Use SAE 10W30 compliant oil or that used to fill the tractor's oil tank

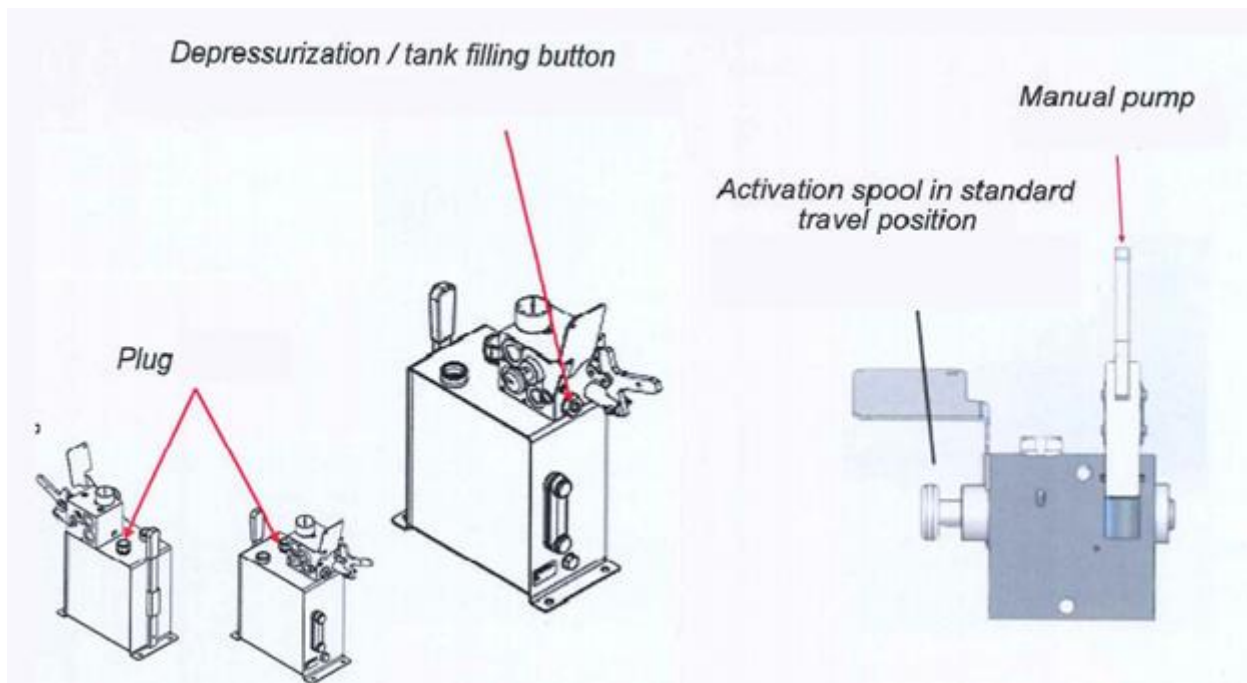

Fig. 14 Location of tank plug, depressurisation button and manual pump.

Check the oil level in the tank regularly: the level must always be between the “max” and “min” positions on the oil level gauge.

If the oil level is below the minimum, follow one of the previously described procedures to refill the tank.

If the oil level is above the maximum, use the manual pump when the trailer is connected to the tractor (the activation spool is in the “normal function position”). Oil will flow from the tank to the tractor’s tank through the secondary line (SL).

If it is difficult to reconnect the tractor’s dual-line connector because of the pressure remaining inside the lines, it is possible to unload the pressure by pressing the depressurisation button for a few seconds. This can happen when the vehicle is left parked in the sun for some time. Excess oil will be drained into the tank and the DLC joint can be connected again.

The depressurisation button can be pressed with tools such as a screwdriver, wrench or lever to the manual pump supplied with the valve assembly kit.

3.5. Hydraulic system quick couplings

The machine’s hydraulic system has quick couplings for quick and easy connection of lines, hoses and the remaining parts of the hydraulic system. Each quick coupling has its own designation (Fig. 15):

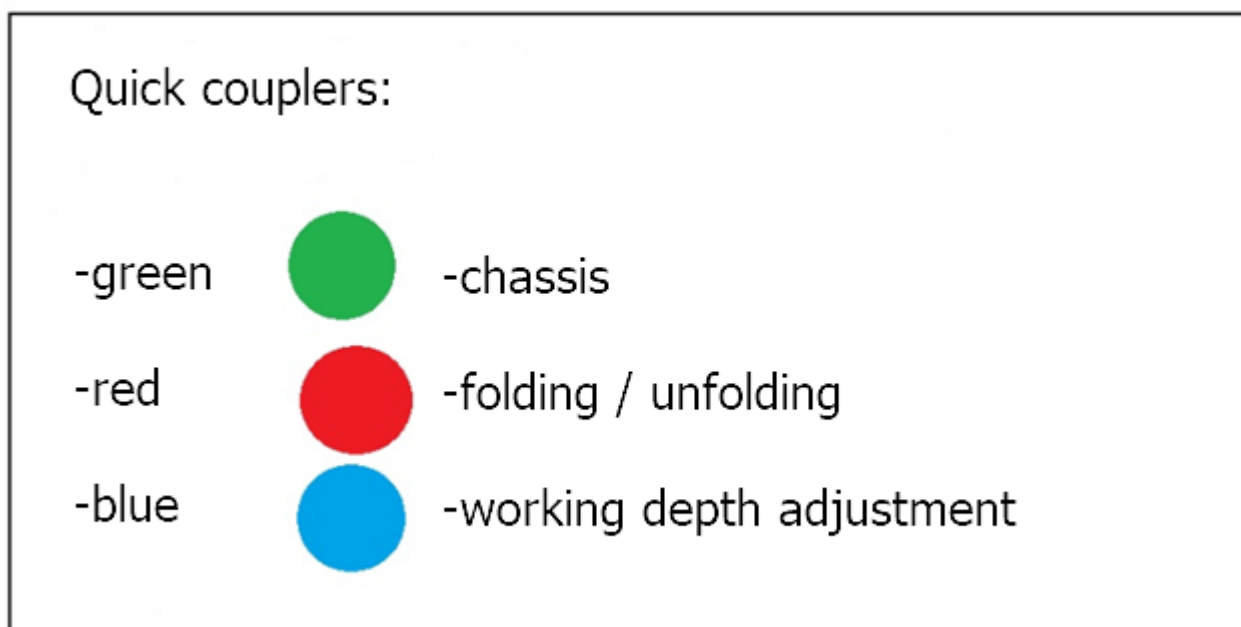

Fig. 15. Designation and purpose of the various quick couplings in the machine.

3.6. Transport safety on public roads

For the period of transport, the side sections of the disc harrow must be put in transport position using the hydraulic system. Before folding, the machine must be lifted sufficiently high until the folded side sections do not collide with the ground.

The disc harrow must be protected against unfolding by means of the mechanical lock.

Lower the wheels so that the side sections do not collide with the ground during folding.

While in transport, the clearance under the machine must be at least 30 cm.

While transporting the implement on public roads, it is absolutely mandatory to use lights, an identification sign and reflective side lights.

Do not exceed the maximum travel speeds:

- up to 20 km/h on smooth (asphalt) roads,
- 6-10 km/h on dirt roads or cobblestones,
- up to 5 km/h on bumpy roads.

After folding the machine, slide the rollers together and secure them with bolts in the ladders in order to achieve a smaller transport width.

Travelling speed must be adapted to the road and the existing conditions so that the disc harrow cannot jump on the tractor suspension system and excessive loads on the machine frame and the tractor suspension system can be avoided.

Act with due caution when passing and overtaking or travelling at curves. The maximum implement width on public roads is 3.0 m.

Do not drive with the implement if the slope is inclined crosswise to the implement by more than 7°.



WARNING! Any failure to observe the above rules may pose hazard to the operator and other people. It may also result in damaging the machine. The user shall be liable for any damage caused by failure to observe the rules!



CAUTION! The machine can exceed 4.0 m at full extension.

3.7. Residual risk description

Mandam Sp. z o.o. makes every effort to eliminate the risk of accidents. However, there is some residual risk that may cause an accident. The biggest hazard occurs when/during:

- using the implement for purposes other than described in the manual,
- operating the implement by people who are underage and do not have licences, are ill or intoxicated,
- presence of people and animals within the implement operating range,
- precautionary measures are not taken during transport and manoeuvring with the tractor,
- anyone gets between the implement and the tractor while the tractor's engine is running,
- maintenance and when the service recommendations are not observed,
- driving on public roads.

3.8. Residual risk assessment

The residual risk can be minimised by applying the following recommendations:

- operate the implement carefully and without undue haste,
- read the instruction manual carefully,
- keep a safe distance from hazard zones,
- do not stay on the implement and within the implement operating range when the engine is running,
- perform the maintenance in accordance with safety rules,
- wear safety clothes and a safety helmet while working under the implement;
- prevent the access of unauthorised personnel and especially children to the implement.

4 Information on operation and use

Before the machine is put into operation for the first time:

- read the instruction manual,
- make sure that the machine is in proper operating condition,
- check the condition of the hydraulic and pneumatic system (replace damaged components, e.g. pressure hoses),
- make sure that the hydraulic hose quick-connectors of the machine match the tractor sockets,
- check the tightening of bolts and nuts,
- check if the air pressure in tyres is according to the manufacturer's recommendations,
- make sure that all components requiring lubrication are lubricated,
- make that the pressure in the tractor wheels is the same on all axles to ensure smooth operation.



CAUTION! The permissible loads on the axles and tyre load capacities must not be exceeded. The front axle load may not be less than 20%.

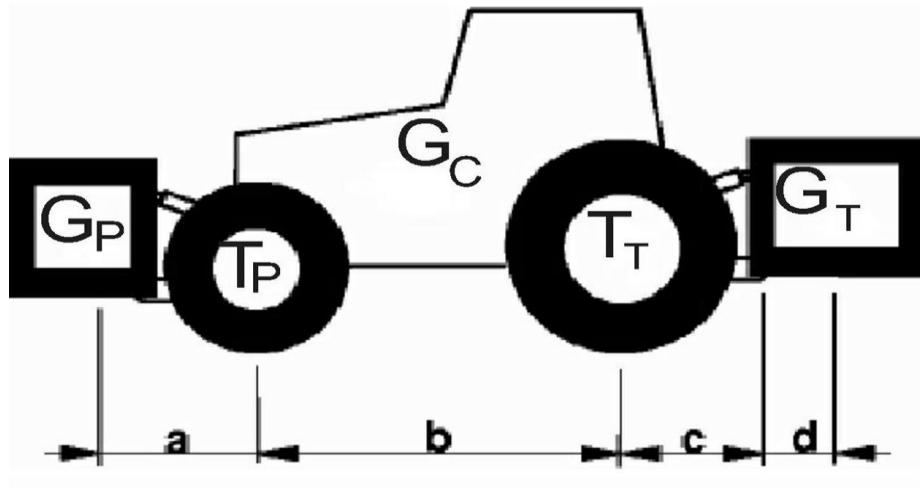

Axle load calculations

Key:

GC - tractor weight,

TP - front axle load for the unhitched tractor,

TT - rear axle load for the unhitched tractor,

GT - total weight of the equipment attached at the back,

GP - total weight of the front-mounted machine,

a - distance between the centre of gravity of the front-mounted equipment and the axle centre,

b - tractor wheelbase,

c - distance between the rear axle centre and the centre point of the hitching pin of the rear-mounted implement,

d - distance of the centre of gravity of the agricultural implement from the hitching pins of the tractor,

x - distance of the centre of gravity from the rear axle (assume 0.45 if the manufacturer does not provide this parameter).

Minimum load at the front in case of a rear-mounted implement:

$$G_{P\min} = \frac{G_T \cdot (c+d) - T_P \cdot b + 0,2 \cdot G_C \cdot b}{a+b}$$

Actual load on the front axle:

$$T_{Pcal} = \frac{G_P \cdot (a+b) + T_P \cdot b - G_T \cdot (c+d)}{b}$$

Actual total weight:

$$G_{cal} = G_P + G_C + G_T$$

Actual load on the rear axle:

$$T_{T\text{ cal}} = G_{\text{ cal}} - T_{P\text{ cal}}$$

4.1. Preparation of the disc harrow

The disc harrow is usually supplied for sale in a ready-to-operate condition. Due to the limitations of the means of transport, it is also possible to deliver it in a partially disassembled condition - usually by disconnecting the roller.

When preparing the unit for operation for the first time, its components (roller) must be assembled. To this end, place the disc harrow on a flat hard surface in a position where the roller can be manoeuvred. A lifting device with a load capacity of at least 500 kg in (700 kg in the case of a rubber roller) must be used for transporting the roller to ensure stability during transport. Position the arms in the harrow holders and connect the arms to the roller clamp using screws (Fig. 16).

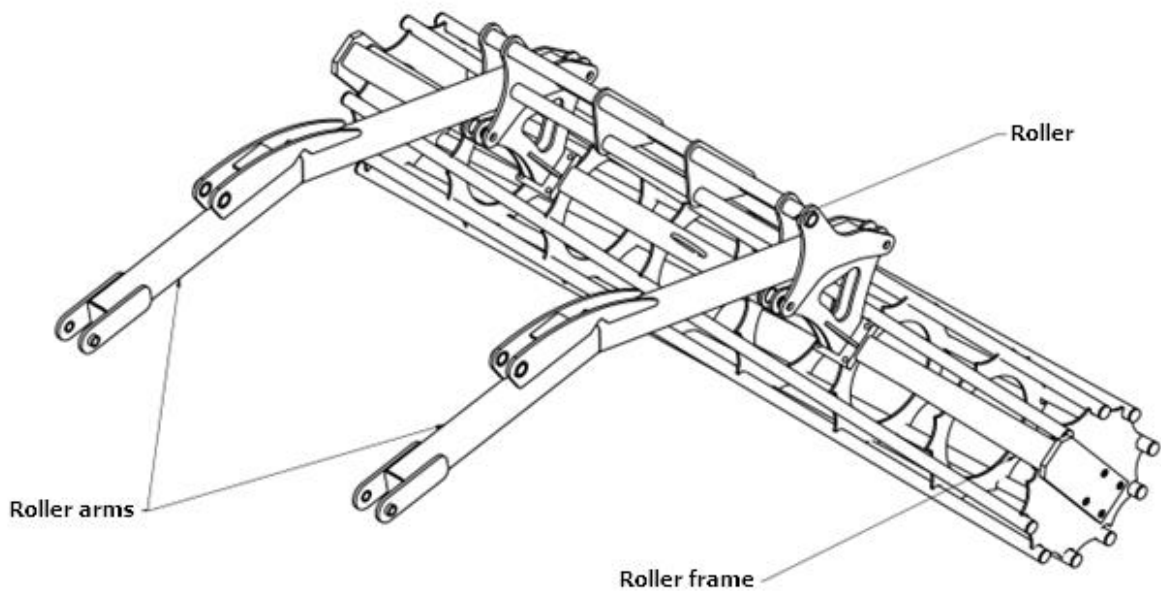

Fig. 16 Arm and roller clamp connection.

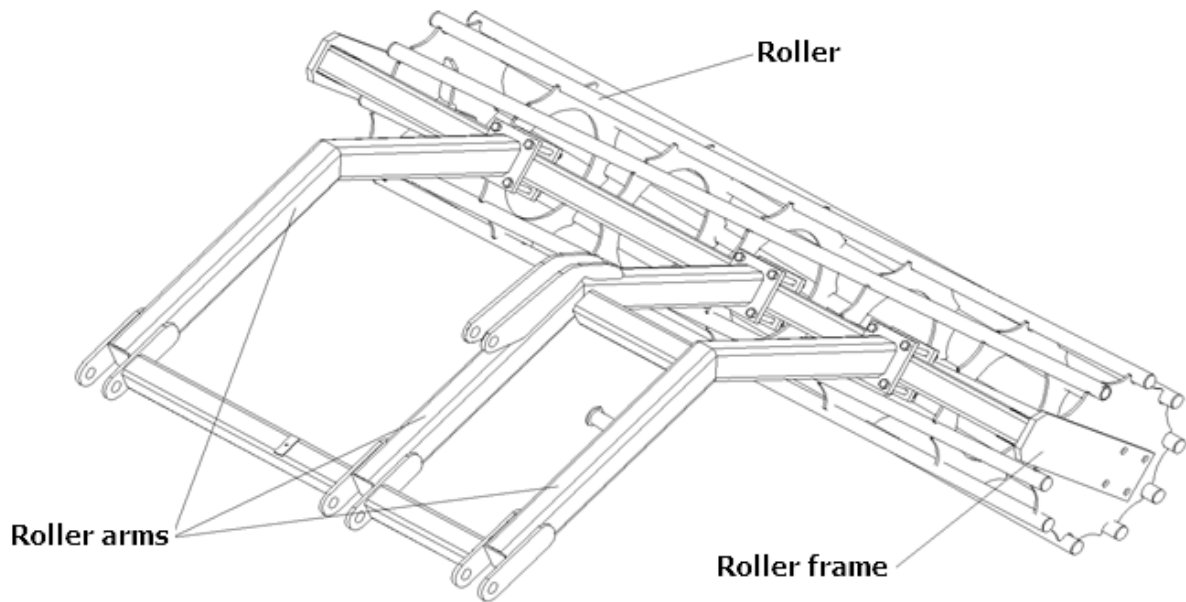

Fig. 17 Arm and roller clamp connection.



CAUTION! The correct procedure for mounting the rollers in the arm clamps requires that the screws are tightened evenly diagonally so that the entire plane of the arm brackets is flush with the plane of the roller clamp profile. This provides the most secure way of connecting the roller arms to the machine!

Prior to operation check the technical condition of the disc harrow, in particular that of the working parts and screw connections.

4.2. Hitching the harrow with the tractor

Tyre pressure in the tractor wheels must comply with the values recommended by the manufacturer. The lower bars of the three-point hitch should be at the same height, spaced correspondingly to the spacing of the lower points of hitch. While attaching the disc harrow to the tractor, the harrow must be placed on hard and even ground.

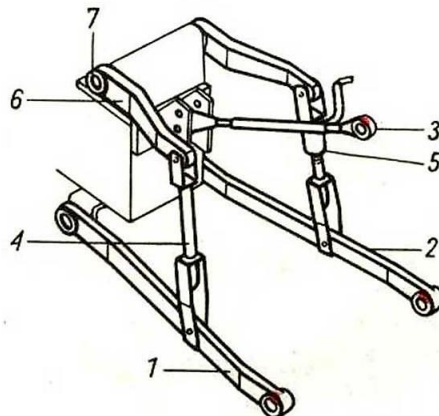

Fig. 18 Three-point hitch of the tractor: 1,2 - lower bars, 3 - upper fastener, 4 - left support rail, 5 - right support rail with adjustable length, 6 - lift arm, 7 - lift shaft.

While attaching the disc harrow to the tractor, complete the following steps:

- switch the tractor hydraulic system into adjustment position,
- uncouple the suspension axle from the implement and attach it to the tractor's lower bars,
- reverse the tractor to a distance that allows the suspension axle to be connected to the frame plates and the upper fastener and harrow support rail,
- secure the suspension axle in the frame plates using the clamps and pins,
- attach the tractor's upper fastener. During operation of the implement, the hitch point of the upper fastener at the implement must be located higher than the attachment point of this fastener at the tractor,
- check the lifting and lowering of the implement.

Each tractor connected to the machine must be equipped with a set of weights and maintain control during transport, i.e. a minimum of 20% of the tractor's weight must be transmitted to the front axle of the tractor.

4.3. Hitching the sower with the disc harrow

Before attaching the sower, check the weight of the sower and the seed. The load capacity of the hydropack is 1,300 kg. When coupling the sower with the disc harrow, proceed as follows:

- adjust the distance between the hooks to the distance between the sower hitching pins by placing the hook on the proper side of the arm and putting the spacer,
- lower the lower bars of the coupling below the sower hitching pins (in case of the coupling on a chassis, insert the pin into the corresponding hole in the support rails of the bar, then adjust the position using the cylinder),
- reverse the set to bring the sower pins into the hooks,
- place the protection cover on the pins and the hook hole and secure with a pin,
- connect the upper fastener with the sower.



CAUTION! Before lifting the disc harrow, the sower must be lifted to ensure the stability of the implement.

4.4. Operation and adjustment

Unlock the mechanical protection of the side frames before unfolding for use. The cylinders are protected by a mechanical lock (Fig. 4). Pull the release ropes and start unfolding. When unfolded, the lock automatically locks in place.

4.4.1 Automatic locking of the machine side extensions

On machines with folding sections, an automatic lock of side extensions is available that requires no additional operation. The lock uses a mechanism consisting of a cylinder and a hook (Fig. 19).

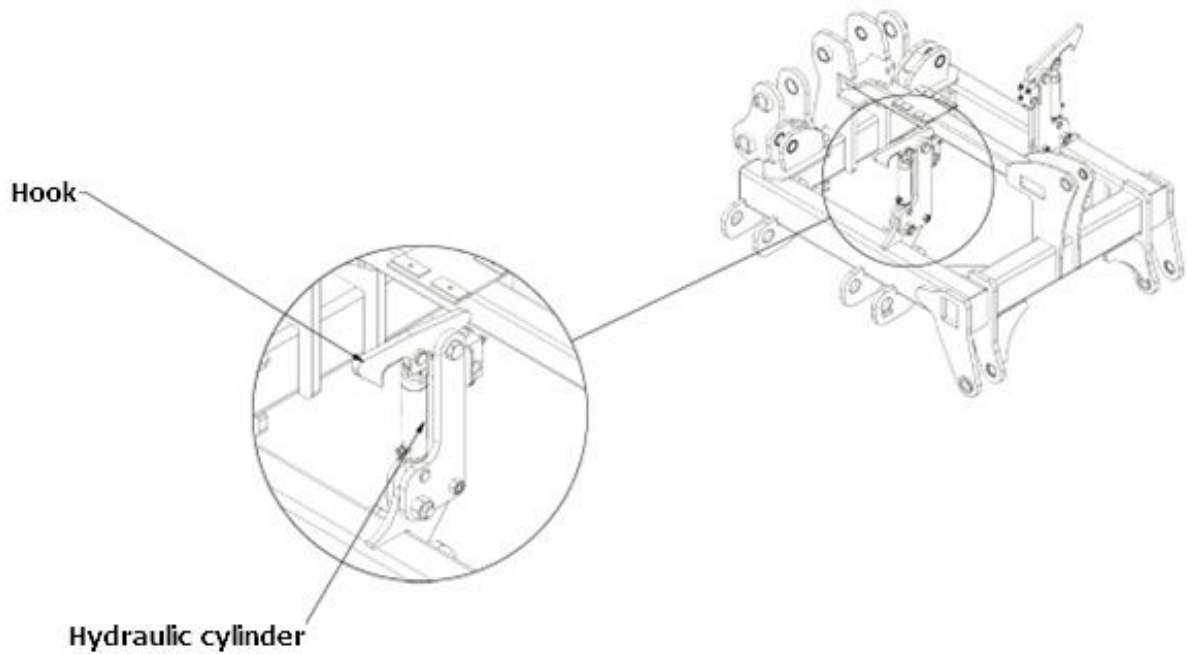

Fig. 19 Main frame with automatic side extension locking mechanism.

4.4.2 Implement opening sequence

Before unfolding the folding side the extensions of the machine, learn the opening sequence to perform this operation correctly.

1. First, raise the implement as much as possible to be able to fold it correctly, avoiding the risk of the folding arms snagging on the ground during movement (Fig. 20).
2. Next, fold the implement side extensions hydraulically into the “closed” position to ensure that the side extension lock mechanism will unlock and allow the implement arms to be opened at a later stage. This operation is necessary each time the arms are opened (Fig. 20).

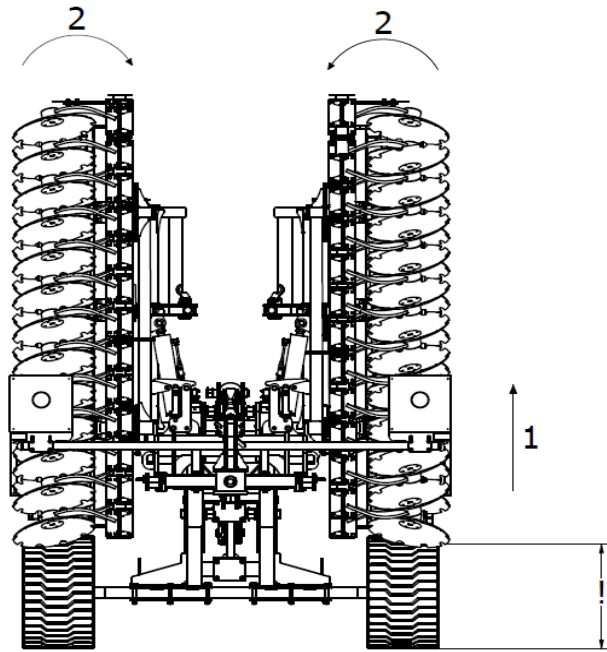

Fig. 20 Implement opening sequence: 1- raise the implement up to the maximum, 2- fold the side extensions into the “closed” position.

3. Then, after making sure that the hook of the hydraulic side extension lock mechanism allows the machine side extensions to be unlocked, proceed to open them fully (Fig. 21).

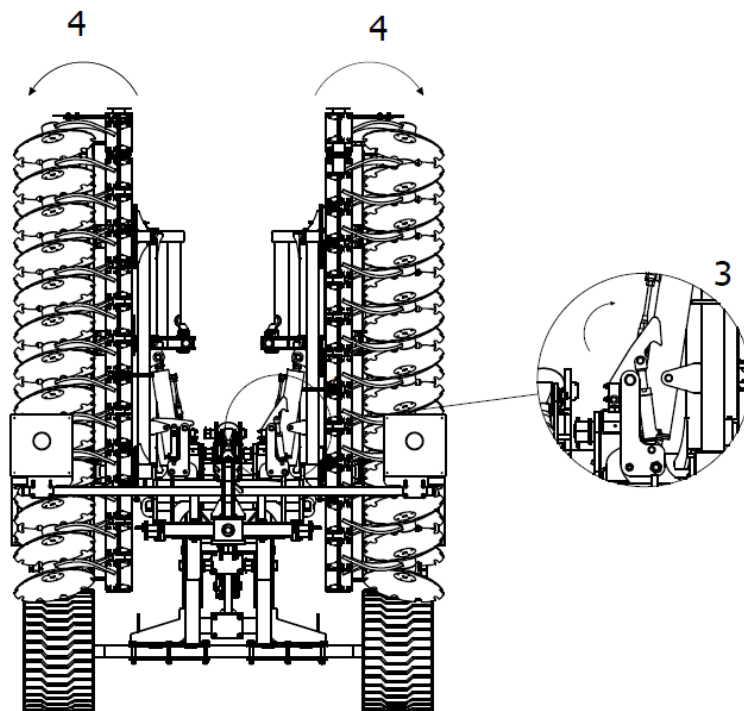

Fig. 21 Implement opening sequence: 3- release the hook of the hydraulic side extension lock mechanism, 4- open the implement side extensions.

4. When opening the implement's side extension arms, make sure that the ends of the arms are at the correct height to prevent them from snagging on the ground (Fig. 22).

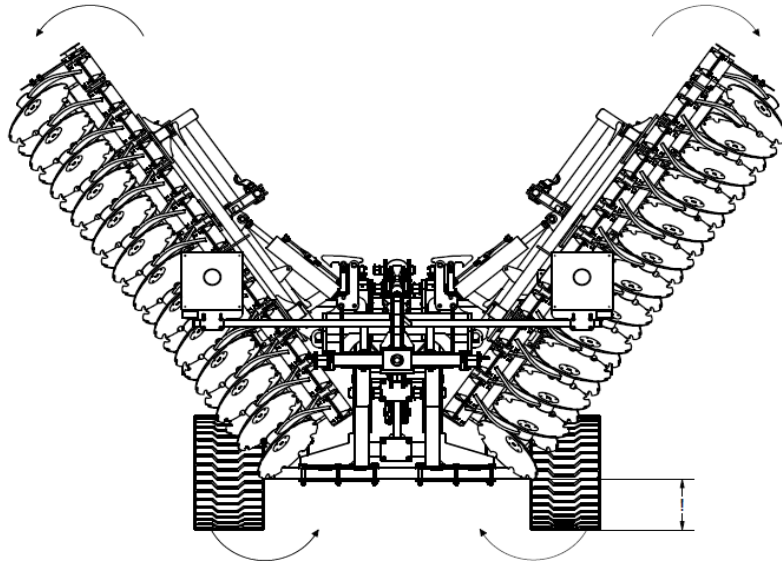

Fig. 22 Implement opening sequence: open the implement paying particular attention to the height of the arm ends from the ground.

5. To complete the opening sequence of the implement side extensions, wait until the hydraulic mechanism opens the arms to their end position. Do not interrupt the opening process of the arm side extensions without ensuring that they are fully open (Fig. 23).

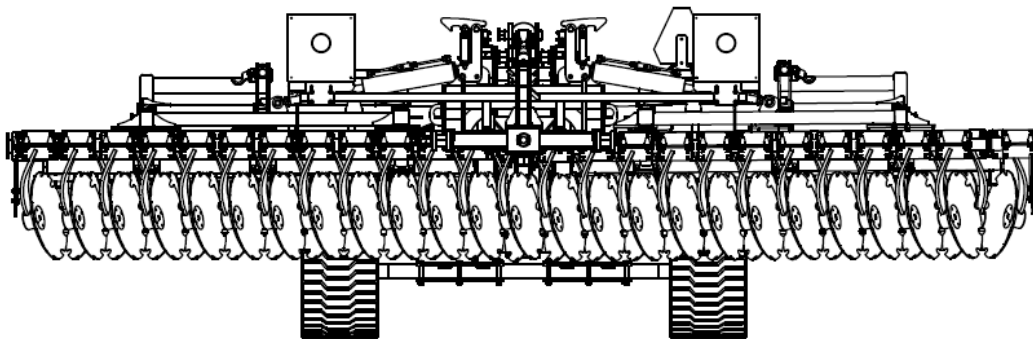

Fig. 23 View of the implement at the completion of the side extension opening sequence. The implement arms are fully open.

4.4.3 Working depth of the BTH disc harrow with BTH-D drawbar

The working depth is determined by the position of the roller the arms of which are

adjustable by the cylinders. In order to maintain a constant stable position of the roller (working depth) during operation, latches are fitted on the cylinder piston (Fig. 24). Initially, set the roller and the wheels above the lower disc edge at the height corresponding to the approximate working depth, and adjust the position during operation, after taking into account the roller recess. The maximum permissible working depth is 15 cm for Ø610 mm discs.

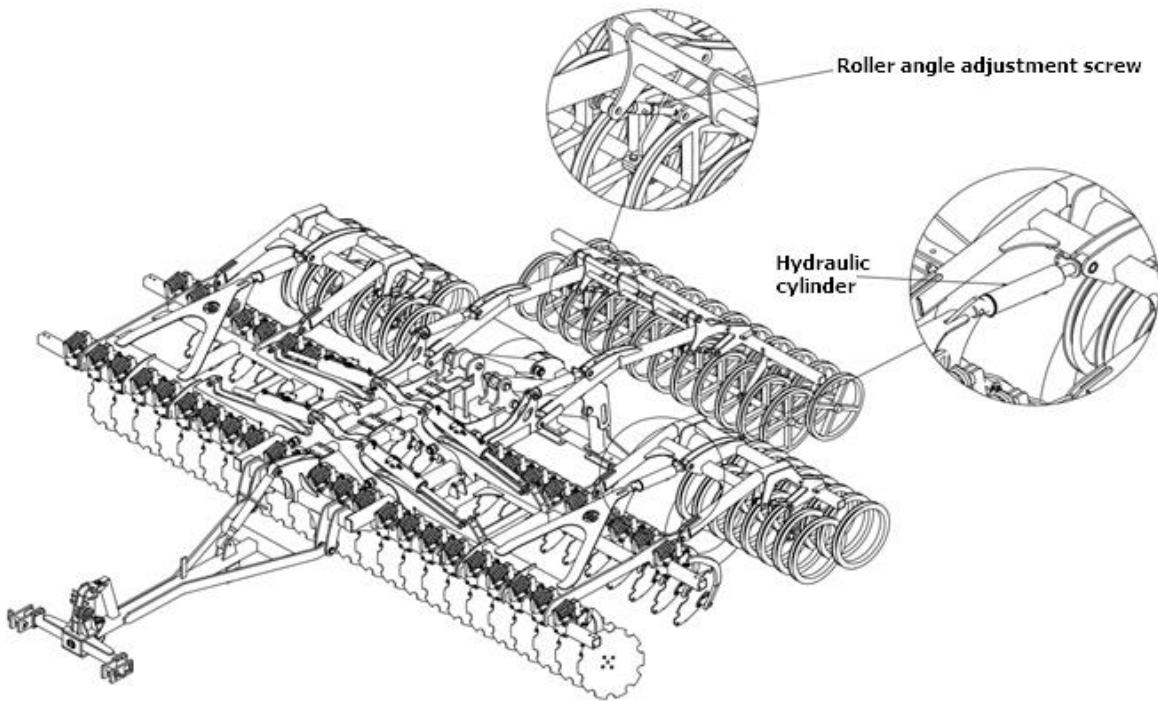

Fig. 24 Hydraulic adjustment of the roller depth.

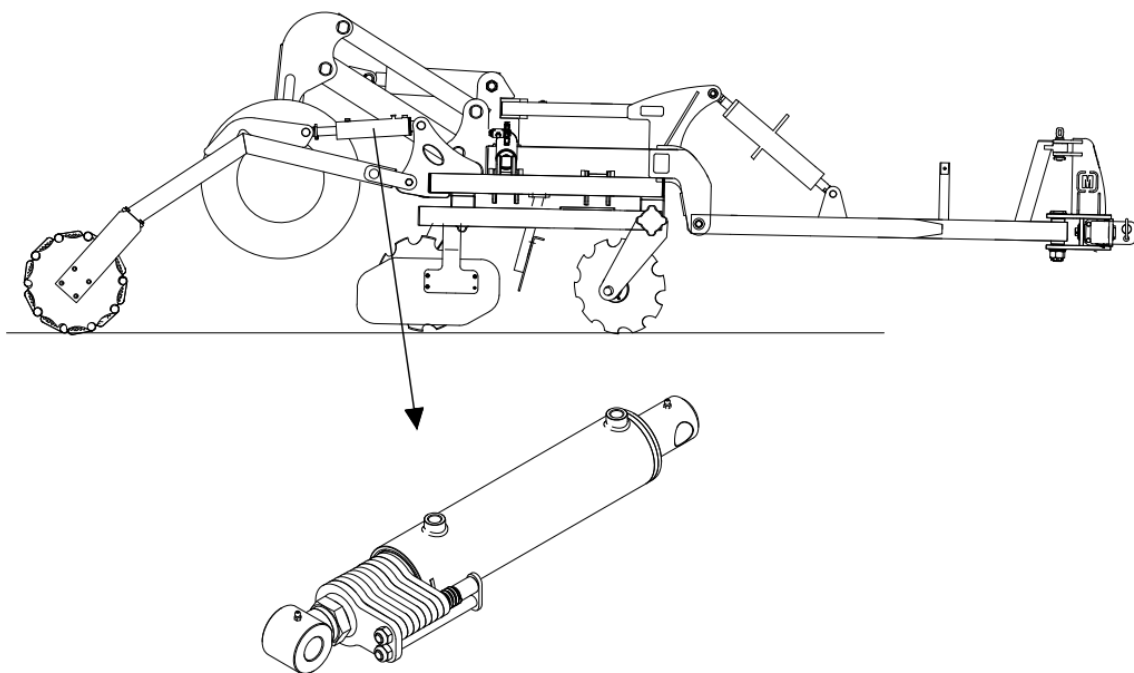

Fig. 25 Cylinder with latches attached to the piston rod to adjust the working depth.

The working depth of the implement is set using latches at the piston rod. As more latches are folded, the operation of the implement becomes shallower. In case none of the latches are installed, the implement operates at maximum working depth. Fig. 26 and Fig. 27 show the correct and incorrect way of installing consecutive latch plates on the cylinder.

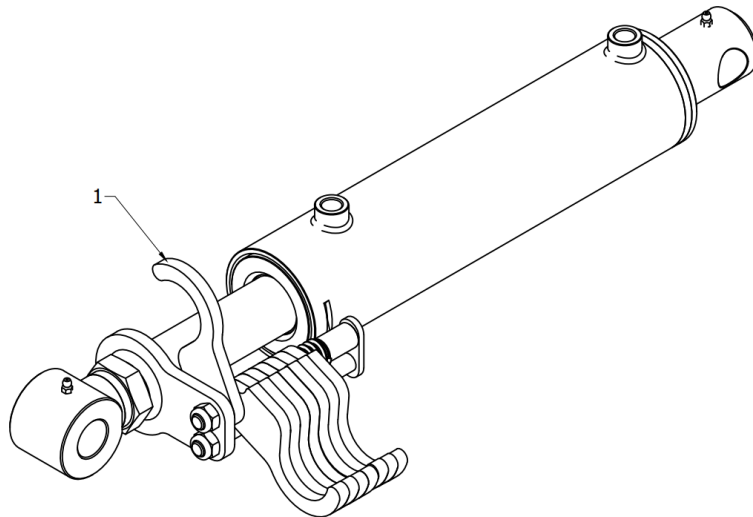

Fig. 26 Correct way to place the first (1) latch on the cylinder piston rod to adjust the implement working depth.

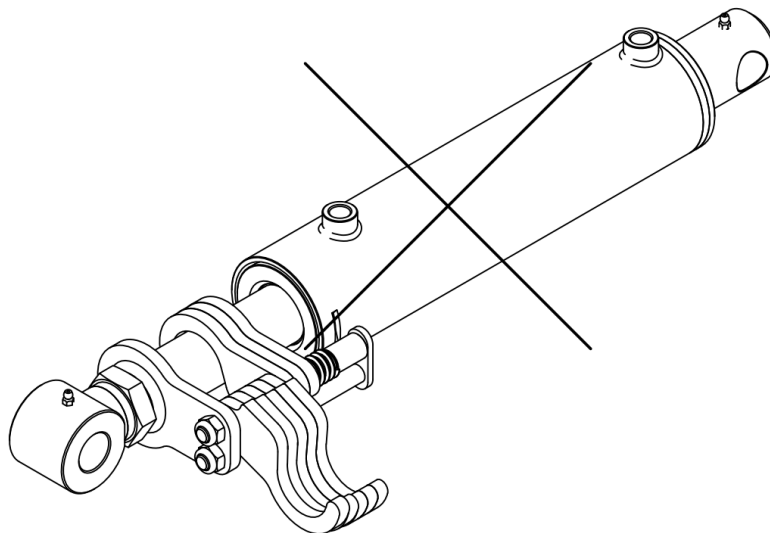

Fig. 27 Latches fitted incorrectly on the cylinder piston rod. If the latches are partially omitted from the cylinder, the forces acting on the piston rod are not evenly distributed and may cause the piston rod to buckle, resulting in damage to the entire piston assembly. This type of adjustment is unacceptable!

Pre-set the positions of the individual working units in the BTH disc harrow before working in the field. Also level the machine lengthwise with the tractor upper fastener or with the drawbar turnbuckle and laterally with the support rail of the right lower bar. **The operating speed should be 10 - 15 km/h.** In a well-adjusted machine, the frame must be parallel to the ground and all working units must be equally recessed in the soil over the entire working width.

The **side plate** must be positioned and locked with the screw so that it is above the soil surface and is not exposed to stones and sticking out of crop residues. If necessary, also slide it forward or backward (re-mounting on the holes) to stop the soil being thrown by the outermost front disc and to pick up the furrow behind the outermost rear disc.

4.5. Rules for transporting the harrow on public roads and lighting the implement

According to the road traffic safety regulations (Regulation of the Minister of Infrastructure of 31 December 2002, Journal of Laws No. 32 of 2002, item 262) - a unit consisting of an agricultural tractor and an agricultural implement hitched with the same must meet the requirements identical to those applying to the tractor itself.



CAUTION! The implement protruding outside the rear side outline of the tractor and obscuring tractor rear lights is a hazard for other vehicles driving on the roads. Be sure to observe the transport instructions specified in chapter 3 “General safety information”. Driving on public roads without adequate marking is forbidden.

The implements must be equipped with:

- triangular board for slow vehicles;
- two boards facing front with a white parking light and a white retroreflector;
- two boards facing rear with composite lamp and a red retroreflector. The plates should be painted in diagonal white and red stripes.

After fixing the plates, connect the electrical cables of the light and signalling device to the tractor’s electrical socket.

The manufacturer does not supply warning plates as standard equipment for the machine. Warning plates are commercially available.

Always adapt your driving style to the road conditions to avoid accidents and damage to the driving system. Take into account your own skills and traffic intensity, visibility and weather conditions.

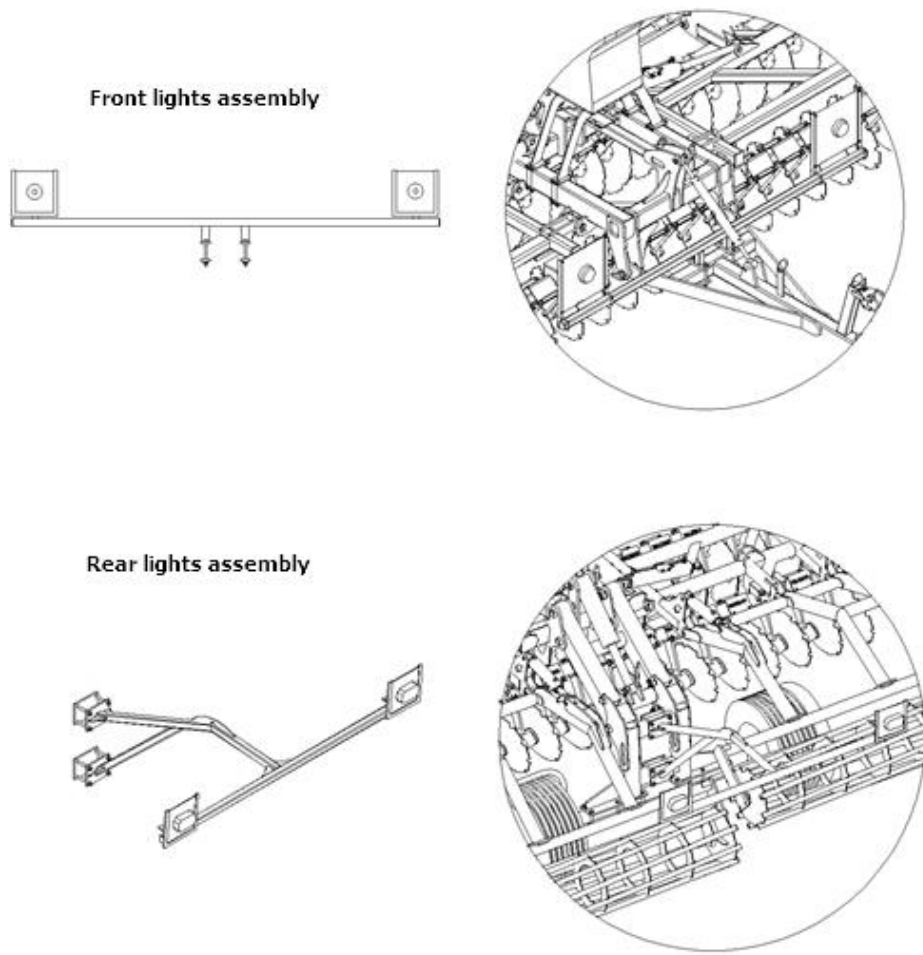
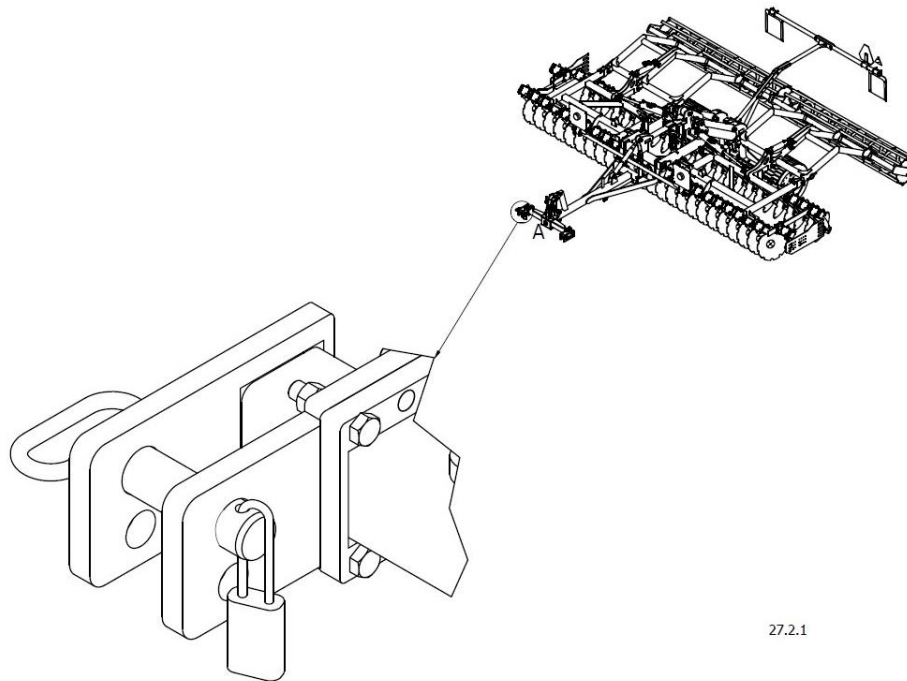

Fig. 28 Front and rear light systems and their position.

Clean the implement from soil residues and check the lights before transporting it. After lifting the machine, check the ground clearance under the lowest working elements, which should be at least 25 cm. The permissible transport speed of the tractor and implement is 15 km/h. It should be 10 km/h in case of poor road surface and 5 km/h on dirt roads. Be particularly careful during overtaking other vehicles, driving around obstacles and driving through large bumps on the field and dirt roads.



27.2.1

Fig. 29 Securing the machine's drawbar fastener with a padlock.

To prevent unauthorised use of the machine, use a security device in the form of a padlock. For this purpose, the safety pin should be locked by the eye of a fastened padlock pinned through the hole inside the pin (Figure 29), preventing it from falling out during operation or transportation.

4.6. Maintenance and lubrication

- Clean the disc harrow from soil after each use and inspect the parts and assemblies. **Otherwise, there may be a problem with the folding of the machine if the rollers are clogged with soil and there is an additional load!**
- After the first 4 hours of operation, re-tighten all bolts and periodically check them for tightness. **Failure to do so will exacerbate play and backlash and result in damage to the implement.**
- Lubricate the lubrication points on the hinge pins daily during the machine's service life. Lubricate the bearings of the tubular roller and the levelling discs every 25 operating hours (not applicable to disc maintenance-free bearings - these bearings do not require maintenance or lubrication).
- Use thread adhesive and only genuine screws and nuts when replacing worn parts.
- Always remember to tighten the screwed joints properly.

CAUTION! Periodic lubrication guarantees the long service life of the machine.

The long service life and efficiency of a machine depends to a large extent on regular lubrication. Use mineral greases for lubrication. Clean the lubrication points thoroughly before pressing or applying grease.

4.7. Screw tightening torque

Screws, bolts and nuts should be tightened in the machine with the appropriate torque depending on the strength class of the bolt and its thread size and pitch. The corresponding torque values for tightening them are shown in Table 3.

Table 3. Screw, bolt and nut tightening torque.

Nuts & bolts torque [Nm]					
		Thread pitch	Nuts & bolts strength grade		
			8.8	10.9	12.9
Size	M4	0,7	3,2	4,5	5,2
	M5	0,8	6	8,4	10
	M6	1,0	11	15	17
	M8	1,3	27	34	40
		1,0	21	30	35
	M10	1,5	46	65	76
		1,3	41	75	67
		1,0	36	50	59
	M12	1,8	79	111	129
		1,3	65	91	107
	M14	2,0	124	174	203
		1,5	104	143	167
	M16	2,0	170	237	277
		1,5	139	196	228
	M18	2,0	258	363	422
		1,5	180	254	296
	M20	2,5	332	469	546
		1,5	229	322	375
	M22	2,5	415	584	682
		1,5	282	397	463
	M24	3,0	576	809	942
		2,0	430	603	706
	M27	3,0	740	1050	1250
		2,0	552	783	933
	M30	3,5	1000	1450	1700
		2,0	745	1080	1270
	M36	4,0	1290	1790	2020
		2,0	960	1340	1500



CAUTION! It is forbidden to work on a damaged machine caused by any event resulting in a broken, or deformed frame, roller or other assembly of the machine!

5 Maintenance of the BTH disc harrow with BTH-D drawbar

Daily maintenance

Thoroughly clean the harrow removing soil and plant residues after each use; inspect the screw, pins and bolt connections and the condition of the operating elements and other parts. When cleaning, remove plant residues and ropes wound at the disc and roller bearing points. Replace any damaged or worn parts. Tighten any loose screw connections and replace damaged cotter pins and pins.

Post-season maintenance

After the end of the working season, thoroughly clean the disc harrow, repair the damaged paint coating and the worn working surfaces of the tines, discs, strings and roller rings as well as the threads of the adjusting screws must be cleaned with “Antykor” kerosene and protected against corrosion with “Antykor 1” grease; moreover, a full lubrication must be carried out. It is recommended to store the machine under a roof during the operational break. However, if this is not possible, check the condition of the protection from time to time and supplement the grease washed away by the rain, if necessary.

Operation of the driving system of the BTH with drawbar BTH-D

Regular checks of tyre pressure. If air leakage in the tyres is considerable, check tightness of the air valve. Next, have the wheel inspected by a specialised company to locate and repair the damage. Considerably damaged tyres (particularly the tyre profile) must be replaced immediately.

Setting the axle clearance of wheel bearings.

It is recommended that this task be carried out by a specialised company. This is done by tightening the nut on the wheel hub once the wheels are dismantled. A clearance of 0.12-0.15 mm is recommended. The inspection and adjustment must be performed every 2 years.

Procedure:

- Dismount the hub cover and the spring pin securing the spring nut.
- At the same time as spinning the hub, press and tighten the crown nut.
- Stop tightening when with a vigorous manual rotation there is no more than a half-turn of the hub.
- Loosen the nut partially until the hub can rotate freely and repeat the tightening step.
- After repeated rotation locking, loosen the nut by max. 30° until the immediate nut locking with a pin is possible. Mark the position with a line.
- From the marked position unscrew the nut a half turn, and slightly tapping on the hub press the hub onto the nut as far as possible.
- Keep tightening the nut until it reaches the position marked with the line.
- Mount the hub cover.



CAUTION! During maintenance, the unit must be secured against rolling away (it must be connected to a tractor with the parking brake on) and unfolded.

Hydraulic system maintenance

Maintenance of the hydraulic system consists in visual inspections for leak tightness. Remember to insert pins into quick-fit connectors. If there is an oil leakage from connections of hydraulic hoses, the connector must be tightened. If the oil leakage is not remedied, replace the component or the hose with a new one. If the leakage occurs outside the connector, replace the leaking hose with a new one. Mechanical damage also requires replacement of the subassembly. It is recommended that the hydraulic hoses be replaced every 5 years.

If oil appears on the piston rod of the hydraulic cylinder, check for the nature of the leakage. Check the sealing once the piston rod is fully moved out. Small leakage which results in covering the piston rod with an oil film is acceptable (damaged wiper seal). If the amount of oil is greater or there are oil drops, shut down the unit for the period required to repair the malfunction (damaged sealing).

Brake system (pneumatic system) maintenance

The three-range braking force distribution system is not adjustable in normal use. It should be in the middle position. If the braking force differs from that of the tractor's braking force, the braking force distribution system may be adjusted to avoid incorrect behaviour of the coupled set on the road. When making any alterations, be sure not to cause an accident or damage to the implement.

The water condensed in the tank is drained using a valve located below the tank. Press the pin down and water will be displaced by compressed air. When the pin is released, the valve will automatically close. Unscrew the drain valve once a year (before winter) and clean it.

The test of the pneumatic system consists in checking for leaks, especially at the connection points (during the test the pressure in the system should not be lower than 6 atmospheres). Any hissing indicates the damage of hoses, gaskets and other components of the system. In the case of small leaks, bubbles will appear (check with a washing liquid).

Damaged components must be replaced.

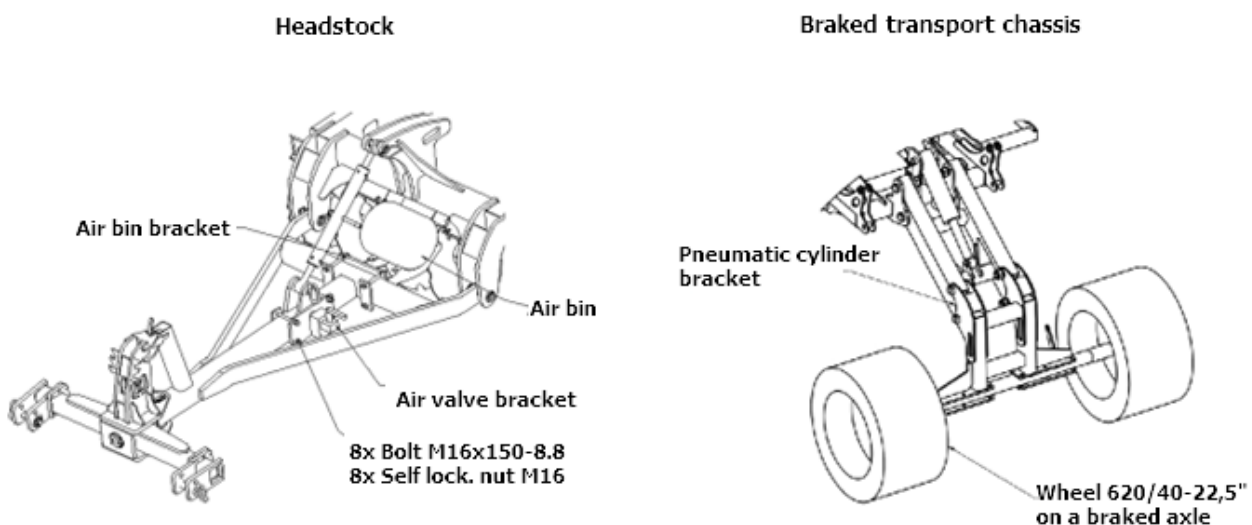

Fig. 30 Pneumatic installation of the brake axle.

Brake control - compensation of the braking deceleration that has to be carried out when:

- the braking force decreases during wear and tear of the brake pad lining during operation and as a result of the resulting play,

- wheel brakes brake unevenly and non-simultaneously.

To this end, change the position of the spreader arm to which the piston of the pneumatic cylinder is acting by changing the initial angle of the spreader shaft at the multi-row end of the shaft and adjust the length of the bar on the screw. Adjustments must be made for each wheel separately.

6 Replacement procedures

Replacement of tubular roller bearings

Replace the damaged bearings following the steps below:

- place the machine on a horizontal surface,
- unscrew the four bolts securing ball bearings on each side,
- move the tubular roller away,
- loosen both headless bolts in each bearing to be able to pull the bearings out with the use of a puller,
- place new bearings on the roller loosely,
- draw the roller between the bearing plates and screw the bearings to the plates, drive the headless bolts with the use of a thread locking glue,
- do not replace the ball bearings on the disc holders,
- in case of damage, replace the entire disc holder.

Replacement of workpieces

Excessively worn workpieces hinder soil penetration by the tools and increase the working resistance. Replace the discs when the diameter has been reduced to 550 mm.

Replace the workpieces on the implement when it is lowered to the ground with the tractor engine stopped. Put sturdy and robust supports (e.g. approx. 20 cm thick wooden blocks under the adjacent workpieces or the roller) to prevent contact between the component to be replaced and the ground. In case of the chassis, the wheels lowered to the maximum position may also be used as supports. Upon lowering the harrow, switching off the tractor engine and applying the hand brake, check the stability of the tractor-implement unit. Use only standard screws to fix new parts or workpieces.

If the components of the machine are disassembled several times, it is necessary to inspect and replace (if required) connecting elements such as bolts, washers or nuts, excessive wear of which can lead to uncontrolled loosening of the connected elements, and consequent damage to the same.

Work with extremely worn work tools can cause, for example, bearing damage in the case of a small disc diameter. Tools should be replaced when their wear and tear exceeds the limits allowed by the manual. Otherwise damage may occur, for which the manufacturer SHALL NOT BE HELD RESPONSIBLE!

Replacement of cylinders

A malfunctioning cylinder (leakage, etc.) must be replaced. Dismount it to have it inspected by a specialised company. Cylinder replacement must be performed when the implement is unfolded. Connect the cylinder to the system and with one side mounted repeat the operating cycle several times until the cylinder is completely filled with oil. Otherwise, the section being lowered may suddenly fall down.



CAUTION Disconnect the unit from the tractor before performing any disassembly activities.



CAUTION! During repairs and maintenance, the implement must be lowered on the ground and be resting on supports ensuring full stability. The tractor engine must be stopped. During repairs and maintenance, use proper spanners and safety gloves.

Table 4. BTH disc harrow - troubleshooting.

Malfunction, defect	Cause	Solution
- uneven penetration of the workpieces	- improper levelling of the implement	- level and align the implement lengthwise and crosswise
- poor disc penetration	- excessively worn discs - roller lowered too low - too low disc pressure on compact soil	- replace the discs - lift the roller
- the stubble not accurately cut	- too low working depth of the discs	- increase the working depth of the discs
- deep groove at the contact point of the work passages	- incorrectly adjusted side plate	- adjust the position of the side plate
- soil flowing above the roller	- rear plate not present - roller placed too close to the discs	- mount the rear plate move the roller away from the discs
- clogging of discs	- excessive working depth	- reduce the depth
- clogging of the side plate	- too much post-harvest residue	- dismount the side plate
- soil poorly pressed by the roller	- harrow poorly levelled - roller raised too high	- extend the upper fastener - lower the roller

7 Storage of the disc harrow

The disc harrow must be stored in a roofed place. If there is no roofed space, external storage is permitted.

The disc harrow must be stored in a place which does not pose any hazard to persons or the environment. If the implement is stored outdoors for a long time, repeat the maintenance activities on the workpieces as soon as the preservative layer disappears. When unhitched from the tractor, the implement must be supported on a firm, level surface with a stable balance. All work units should rest on the ground. Lower the implement gently so that it does not come into contact with hard surfaces. When lowering the implement, unhitch the suspension system and drive away the tractor. Also, the parts that have been disassembled and removed from the implement must be stored securely supported on the ground to prevent uncontrolled movement. It is advisable to store the implement on a hardened firm surface in roofed areas, inaccessible to unauthorised persons, bystanders and animals.



Store the machine firmly supported on a hardened firm surface so that no injury is caused to persons or animals.

Clean the piston rods of the hydraulic cylinders during winter and when the machine is not in use for a long period of time, and protect them from corrosion with vaseline or acid-free grease.

8 Disassembly and withdrawal from service and scrapping

When operated in accordance with the guidelines in the instruction manual, the implement will have a long service life, however worn or damaged parts must be replaced. In the event of emergency damage (cracks and deformation of the frames) impairing the quality of the machine operation and posing a risk to its further operation, the machine must be withdrawn from service.

Disassembly of the implement should be carried out by persons who are familiar with its design. These operations must be performed when the machine is placed on level, firm ground. Disassembled metal parts should be scrapped and rubber parts should be handed over to a disposal plant. The oil must be drained into a tight container and disposed of at a disposal plant.



CAUTION Take all precautions during the disassembly: use appropriate tools and personal protective equipment. Dispose of the disassembled parts in accordance with the environmental protection requirements.

9 Spare parts for the BTH disc harrow with BTH-D drawbar

In order to search, find prices and order original spare parts visit our website at www.mandam.com.pl, “parts” tab.

There you can find catalogues and spare part sheets in PDF format, containing current part drawings and diagrams for each machine or implement, together with part numbers and prices.

Purchase orders for parts can be placed or enquiries related to the same can be sent directly from this website (tab: “contact/order”), or sent to the following e-mail address: czesci@mandam.com.pl

A purchase order should contain part numbers and quantities, as well as details of the ordering party/payer together with a contact phone number.

The parts are sent directly to the specified address on the COD basis.

If in doubt, please contact Mandam Spare Parts Department at: +48 32-232-2660 extension 39 or 45 or at + 48 668-66-22-89 (mobile).

Original MANDAM spare parts are also available from all authorised MANDAM distributors.