

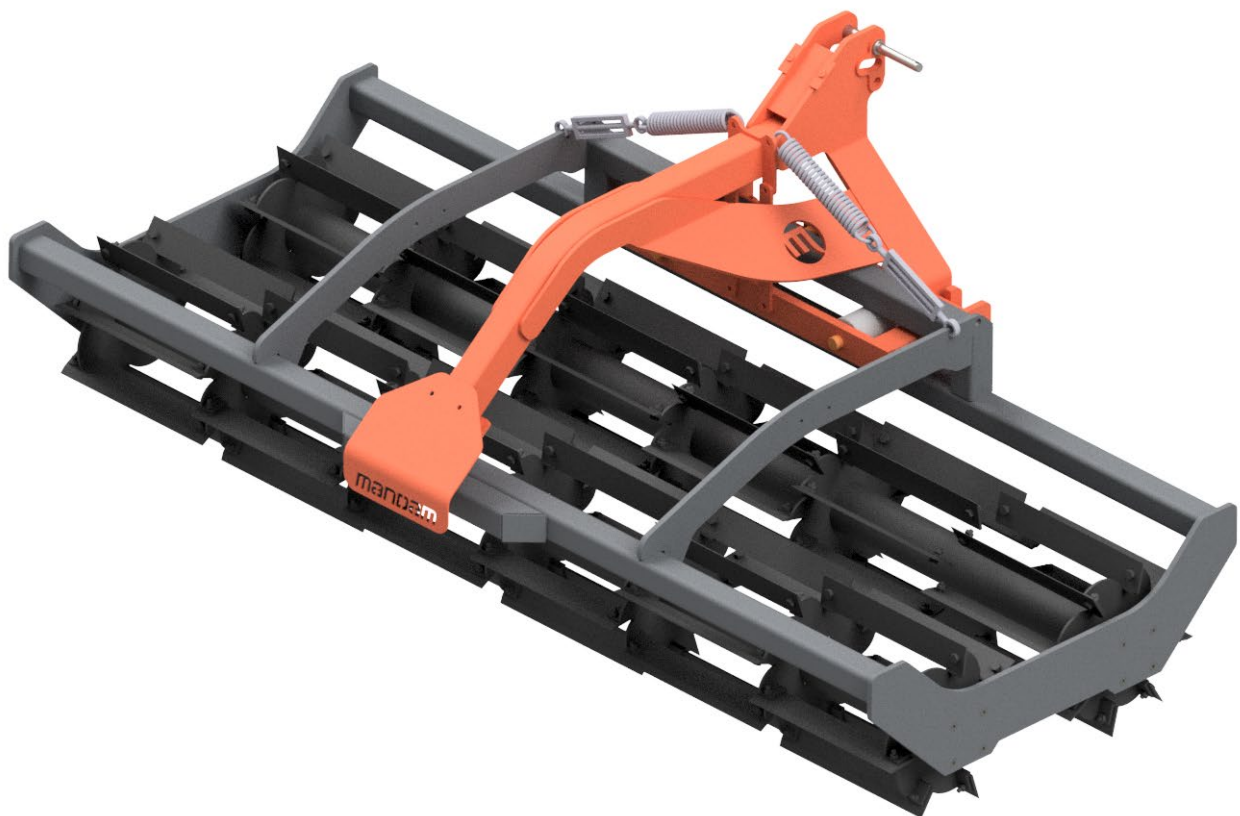

MANDAM Sp. z o.o.  
ul. Toruńska 14 44-100 Gliwice, Poland  
e-mail [mandam@mandam.com.pl](mailto:mandam@mandam.com.pl)  
Phone: 032 232 26 60 Fax: 032 232 58 85  
NIP (Tax ID): 648 000 16 74 REGON (Registration no.): P - 008173131

## INSTRUCTION MANUAL

# KNIFE ROLLER / TANDEM KNIFE ROLLER / TANDEM HD KNIFE ROLLER



Issue III  
Gliwice 2022



# EC DECLARATION OF CONFORMITY



## FOR A MACHINE

In accordance with the Ordinance of the Minister of the Economy dated 21 October 2008 (Journal of Laws No. 199, item 1228) and the Directive of the European Union no. 2006/42/EC of 17 May 2006

**"MANDAM" Sp. z o.o.**

**ul. Toruńska 14**

**44-100 Gliwice**

**hereby declares at its sole responsibility that the following machine:**

type/model: .....

serial number:

year of manufacture: .....

under this declaration, complies with:

the **Ordinance** of the Ministry of Economy of 21 October 2008 on fundamental requirements for machinery (Journal of Laws No. 199, item 1228) and the **Directive** of the European Union 2006/42/EC of 17 May 2006.

Persons responsible for the technical documentation for the machine: Jarosław Kudlek, Łukasz Jakus

ul. Toruńska 2, 44-100 Gliwice, Poland

**For assessment of compliance the following standards have been applied:**

PN-EN ISO 13857:2010

PN-EN ISO 4254-1:2016-02

PN-EN ISO 12100-1:2005/A1:2012

PN-EN ISO 12100-2:2005/A1:2012

PN-EN 982+A1:2008

This EC Declaration of Conformity shall be cancelled if the machine is modified or redesigned without consent of the manufacturer.

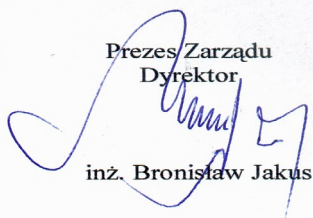
Prezes Zarządu  
Dyrektor  
  
inż. Bronisław Jakus

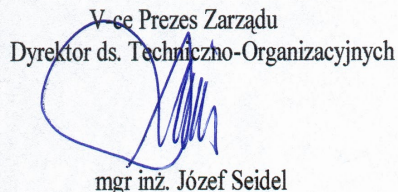
V-ce Prezes Zarządu  
Dyrektor ds. Techniczno-Organizacyjnych  
  
mgr inż. Józef Seidel

.....  
Place and date of issue

.....  
First and last name, position held and signature of the person authorized

1. Introduction.....	4
1.1. Safety signs and inscriptions .....	5
2. General information.....	7
2.1. Knife roller design.....	7
3. General safety information .....	13
3.1. Hitching with the tractor.....	14
3.2. Hydraulic system.....	14
3.3. Transport on public roads .....	14
3.4. Description of residual risk .....	15
3.5. Residual risk assessment .....	15
4. General information on the use of the implement .....	16
4.1. Hitching the roller with the tractor .....	17
4.2. Operation and adjustment.....	18
4.2.1 Setting the knife direction .....	18
4.3. Maintenance and lubrication .....	20
5. Technical maintenance.....	21
5.1. Hydraulic system maintenance (knife roller H) .....	21
5.2. Defects and malfunctions in the roller operation .....	22
6. Roller storage.....	23
7. Roller transport.....	23
8. Disassembly and withdrawal from service and scrapping.....	24
9. Knife roller spare parts .....	24

## 1. Introduction

Congratulations on your purchase of the knife roller.

This instruction manual provides information on the hazards that may occur during use, knife roller operation, technical data and the most important indications and recommendations, the knowledge and use of which is a prerequisite for proper operation. Keep this manual for future reference. Should you have any problems with understanding any statement in the instruction manual, please contact the manufacturer.

The following mark indicates the guidelines that are important due to safety reasons:



### Machine identification

Identification data of the roller, including basic information on the manufacturer and the machine and CE marking, can be found on the rating plate placed on the load-bearing frame.

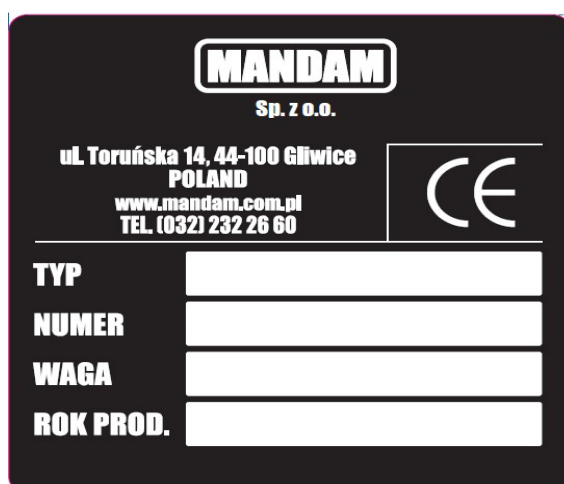

The warranty for the knife roller is valid for 24 months and runs from the date of sale.

The warranty card constitutes an integral part of the machine.

Always provide the serial number when submitting inquiries for spare parts.

For more information on spare parts:

- please visit our website at: <http://mandam.com.pl/parts/>
- call us at +48 668 662 289
- e-mail us at: [czesci@mandam.com](mailto:czesci@mandam.com)





## 1.1. Safety signs and inscriptions



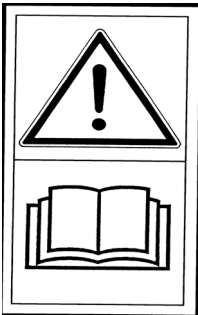

**Remember! Special care must be taken when using the roller in case of areas marked with special information and warning signs (yellow stickers).**

The following symbols and inscriptions can be found on the implement. Secure the signs and inscriptions against loss and make sure they are legible at all times. *If lost or illegible, replace the signs and inscriptions with new ones.*

Table 1. Information and warning signs

Safety sign	Meaning of the safety sign	Location on the implement
	Read the instruction manual prior to operating the implement.	Frame adjacent to the mounting place of the upper fastener
	Danger of toe or foot crush.	Frame adjacent to the mounting place of the upper fastener
	Keep clear from lift bars while controlling the lift.	Frame adjacent to the mounting place of the upper fastener
	Keep clear from foldable and moving parts of the implement.	Front part of the mid frame adjacent to side frames

Safety sign	Meaning of the safety sign	Location on the implement
	<p>Do not reach into the crushing zone if the elements can move</p>	<p>Middle frame adjacent to side frames</p>
	<p>Pressurized fluid - hazard of bodily injury</p>	<p>Cylinders</p>
	<p>Fixing point for transport belts</p>	<p>Upper part of the drawbar (upper fastener bolt)  Rear part of the frame:</p> <ul style="list-style-type: none"> <li>• rigid frame (adjacent to the roller depth adjustment)</li> <li>• foldable frame (adjacent to the cylinder bolt on the mid frame)</li> </ul>

## 2. General information

### 2.1. Knife roller design

Knife rollers are available in single and tandem versions, in the working widths of 3.0 m, 3.5 m, 4.0 m, 5.0 m and 6.0 m.

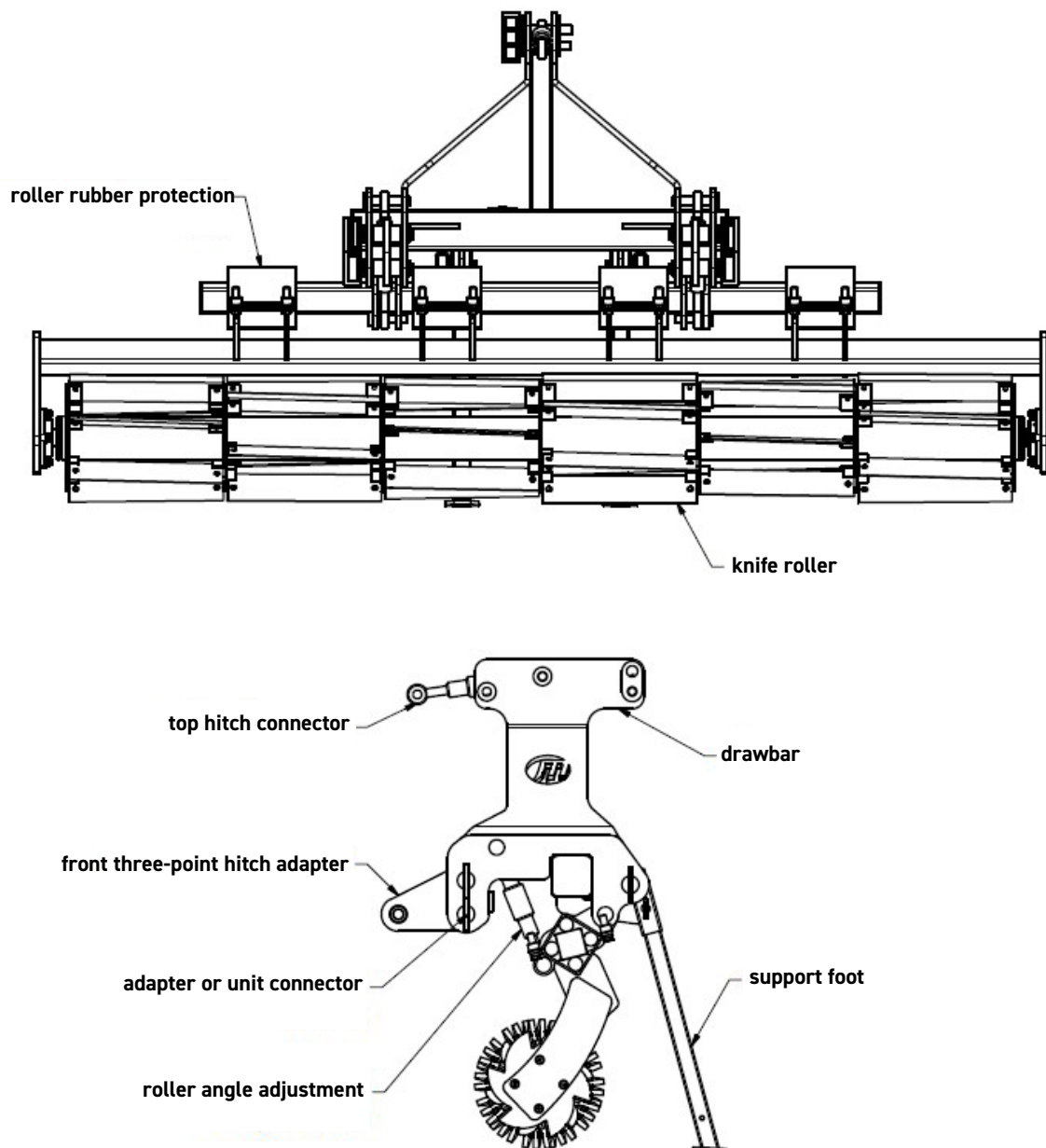

Fig. 1 Knife roller 3.0

Table 2. Single knife rollers

Type	Working width [m]	Roller diameter [mm]	Min. power demand [HP]	Weight [kg]
KNIFE ROLLER 3.0	3	380	30	552
KNIFE ROLLER 3.5	3.5	380	35	644
KNIFE ROLLER 4.0	4	380	40	920
KNIFE ROLLER 4.0 H	4	380	40	968
KNIFE ROLLER 5.0 H	5	380	50	1102
KNIFE ROLLER 6.0 H	6	380	60	172

Table 3. Tandem knife rollers

Type	Working width [m]	Roller diameter [mm]	Min. power demand [HP]	Weight [kg]
TANDEM KNIFE ROLLER 3.0	3	460	60	800
TANDEM KNIFE ROLLER 3.5	3.5	460	65	933
TANDEM KNIFE ROLLER 4.0	4	460	80	1060
TANDEM KNIFE ROLLER 4.0 H	4	460	80	1180
TANDEM KNIFE ROLLER 5.0 H	5	460	100	1390
TANDEM KNIFE ROLLER 6.0 H	6	460	120	1600

Table 4. Tandem knife rollers HD

Type	Working width [m]	Roller diameter [mm]	Min. power demand [HP]	Weight [kg]
TANDEM KNIFE ROLLER HD 3.0	3	560	60	1020
TANDEM KNIFE ROLLER HD 3.5	3.5	560	65	1260
TANDEM KNIFE ROLLER HD 4.0	4	560	80	1330
TANDEM KNIFE ROLLER HD 4.0 H	4	560	80	1520
TANDEM KNIFE ROLLER HD 5.0 H	5	560	100	1770
TANDEM KNIFE ROLLER HD 6.0 H	6	560	120	1980



The single knife rollers 3.0, 3.5 and 4.0 are not foldable and are attached to the front or rear tractor three-point hitch. When attached to the rear three-point hitch, it is possible to suspend an additional unit behind the roller, e.g. a disc harrow. The front three-point hitch adapter should be removed in such case and an additional unit should be attached in its place using bolts.

The Tandem foldable knife rollers in the working width of 4.0, 5.0 and 6.0 are adapted to be attached to the front three-point hitch. They also feature a floating drawbar stabilized with springs. When the pins are properly interlocked and the working rollers are rotated, it is possible for the roller to work on the tractor's rear hitch.

The single and tandem knife rollers with working widths 4.0H, 5.0H and 6.0H have a middle frame and lateral frames which are hydraulically folded to the transport position (Fig. 3 and 4).

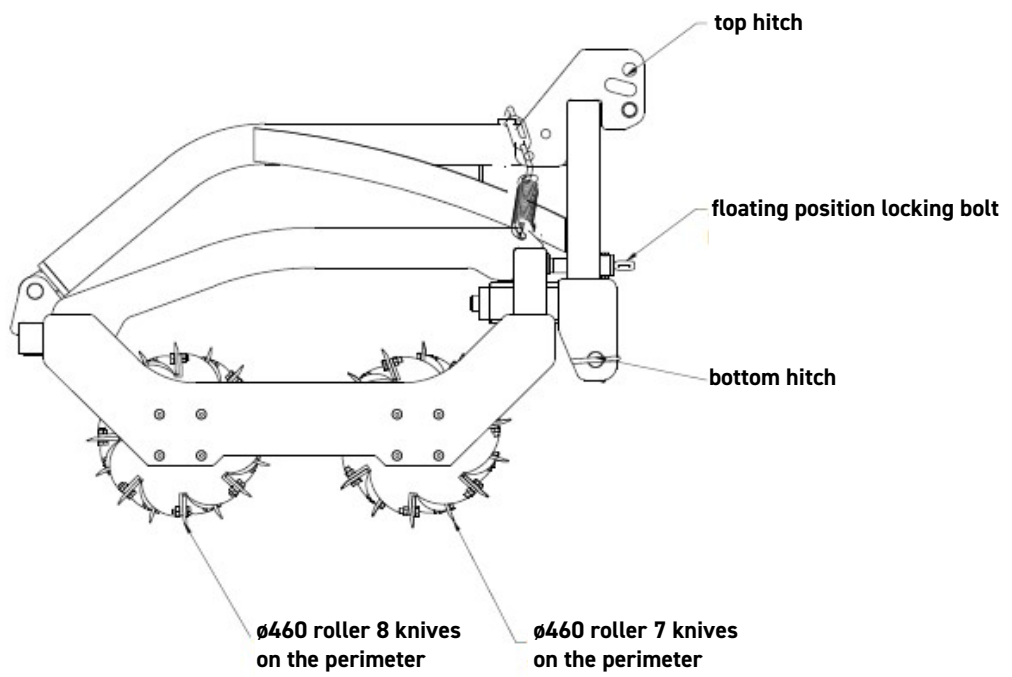
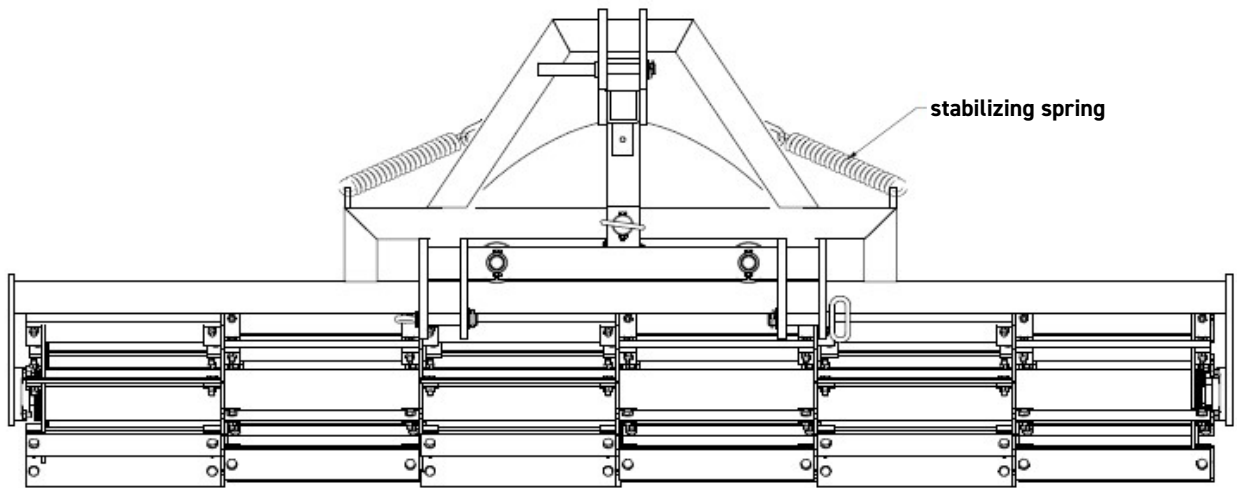

Fig. 2 Tandem knife roller 3.0

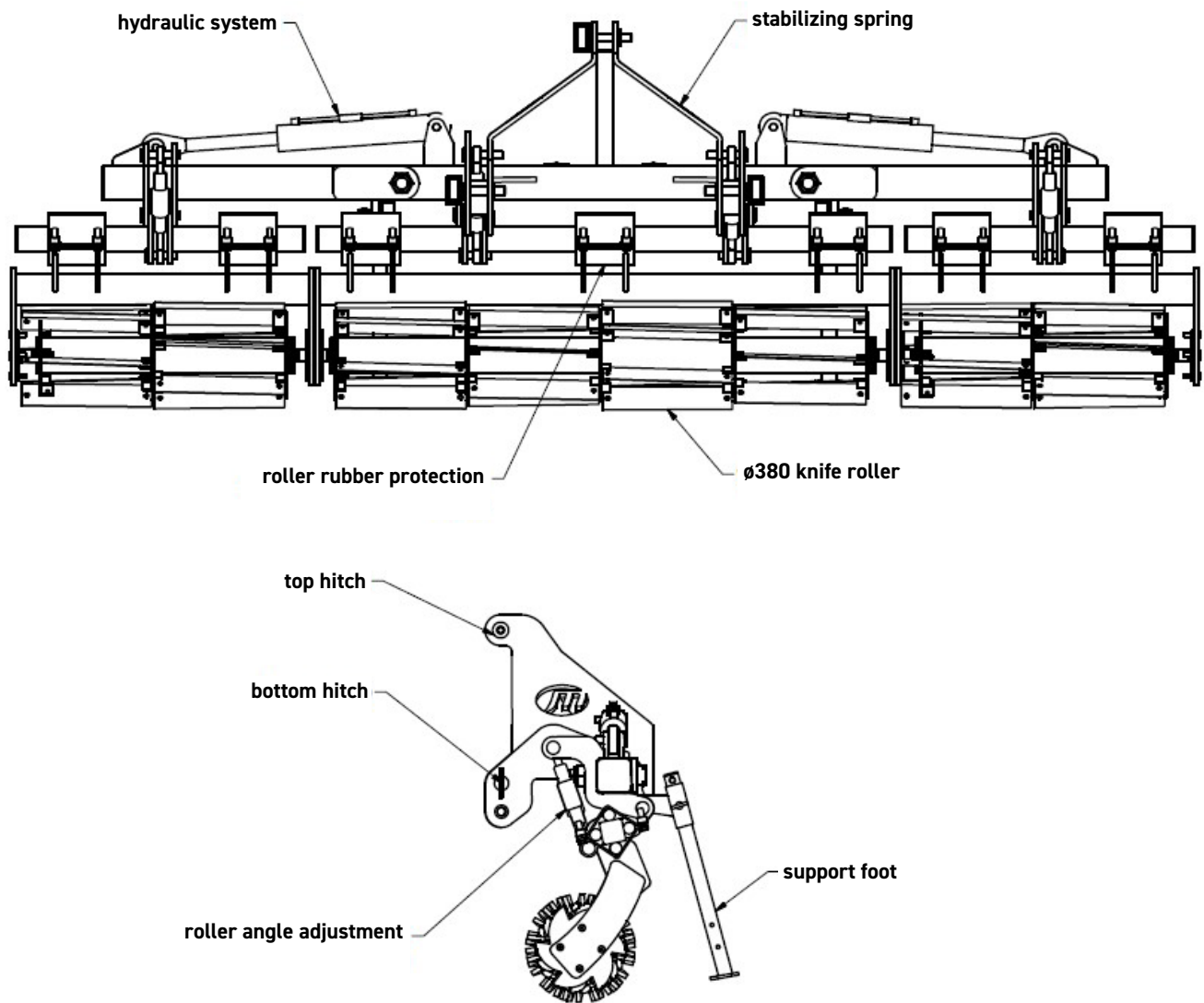

Fig. 3 Knife roller 4.0 H

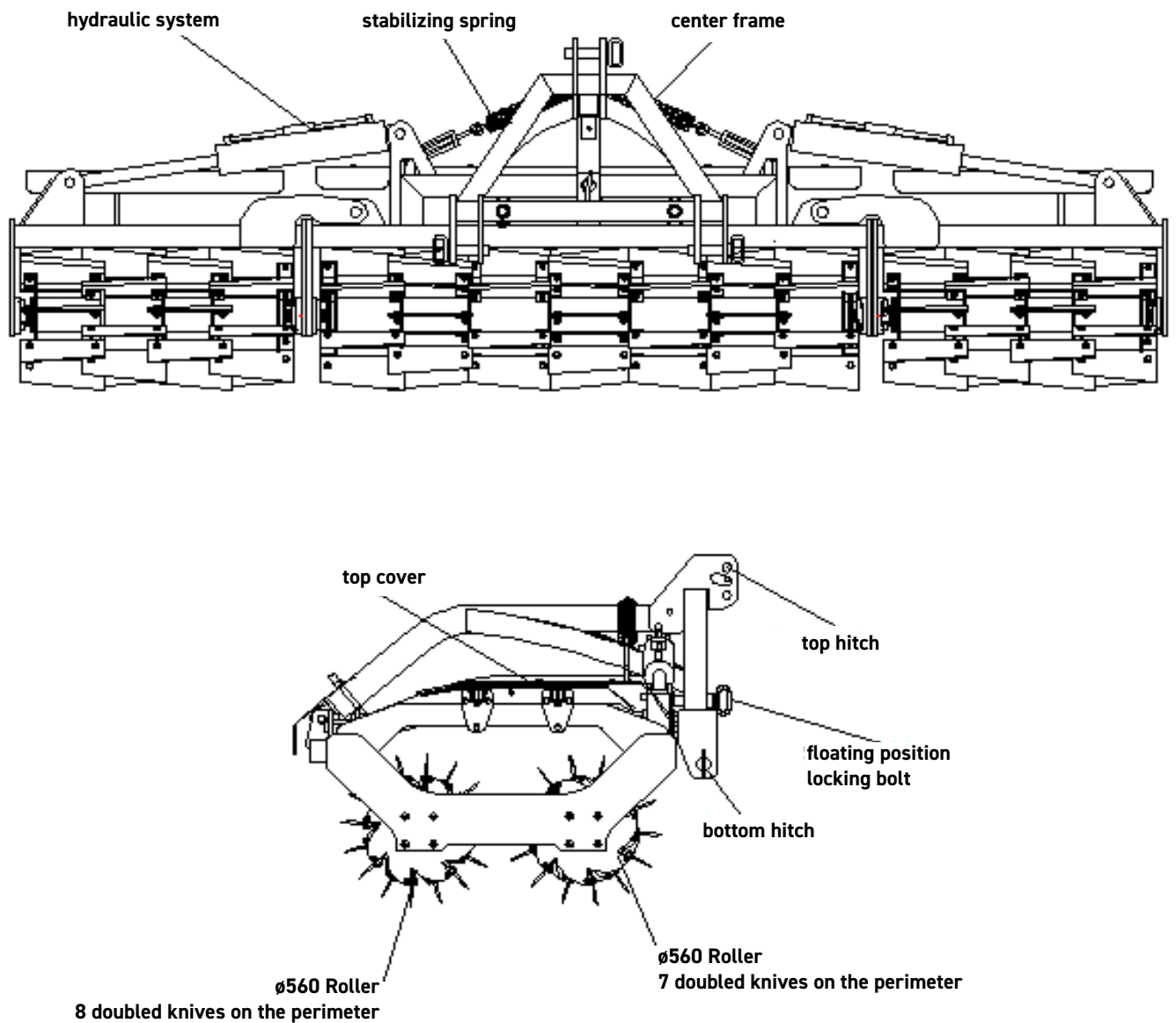

Fig. 4 Tandem knife roller HD 4.0 H

## 2.2 Intended use of the knife roller

The knife roller is used for an intensive shredding of straw and post-harvest crop residue, along with crushing and partial covering. This speeds up the decomposition of crop residue, facilitating further post-harvest cultivation. The knife roller is also a perfect tool for fighting the European corn borer.

**The working part of the roller is an openwork drum with cutting knives bolted on its circumference. The knives are made of the HARDOX wear resistant steel. The knives should operate on the field surface. The knife roller shall not penetrate into the soil deeper than 2-3 cm.**



**CAUTION!** The roller is designed for agricultural use only. Using the implement for tasks that differ from the intended use shall be regarded as misuse, resulting in loss of warranty.



**CAUTION!** Failure to follow the guidelines included in this instruction manual shall be regarded as misuse. The manufacturer shall not be liable for any damage arising out of misuse.

As an option, single and tandem knife rollers can be equipped with frame-mounted upper covers to protect the tractor from the spread of post-harvest crop residue or stones caused by the working rollers. On tandem knife rollers HD, these protection covers are mounted on the machines as standard.

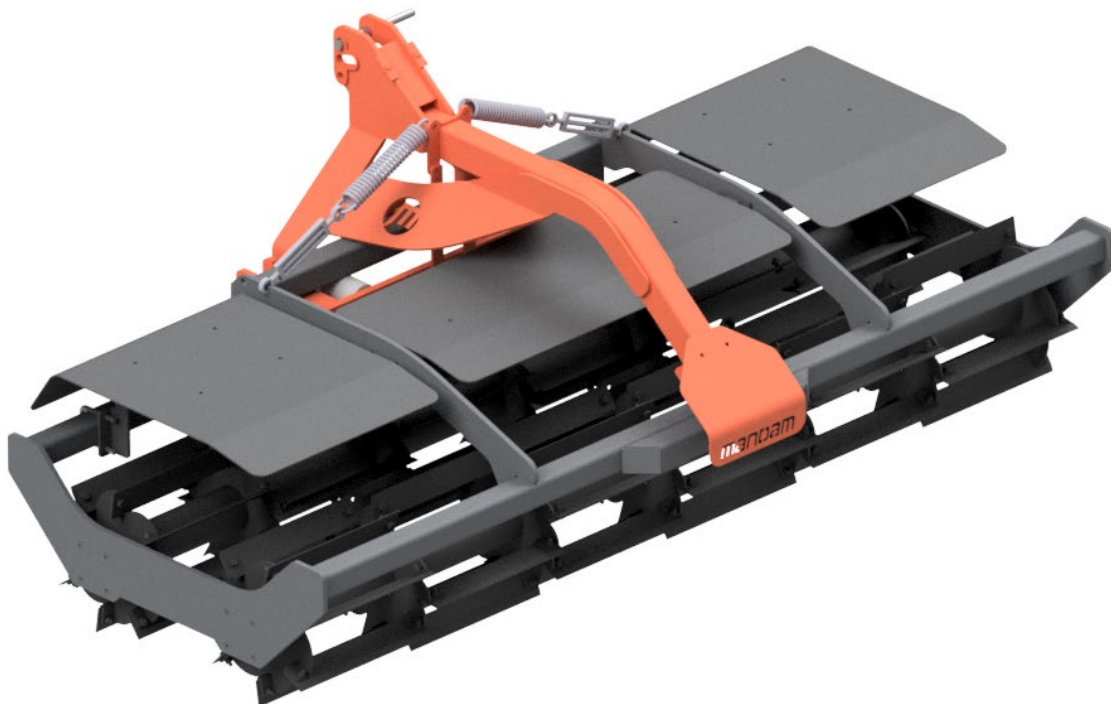

Fig. 5 Tandem knife roller 3.0 with upper protection covers

### 3. General safety information

The roller can be operated and repaired only by persons familiar with its operation and the attached tractor as well as the rules of safe operation and maintenance of the knife roller. The manufacturer shall not be responsible for any arbitrary modifications of the construction of the roller. Only genuine MANDAM spare parts shall be used during the warranty period.

The roller must be operated with all precautionary measures, in particular:

- each time before starting operation check the roller and the tractor whether their condition guarantees safety during operation and travel,
- minors, disabled or intoxicated persons (under the influence of alcohol or drugs) must not operate the machine,
- wear work clothes, shoes and gloves during maintenance,
- do not exceed permissible axle and tyre loads or transport dimensions,
- use only original cotter pins and pins,
- do not approach the roller while it is being lifted or lowered,
- do not stay between the roller and the tractor while the engine is running,

- move forward, lift, and lower the roller slowly and smoothly without sudden jerks, making sure that nobody stays in the vicinity,
- do not reverse and make U-turns when the implement is lowered to the working position,
- when making U-turns do not use independent tractor brakes,
- do not stand on the implement or apply additional loads during operation and transport,
- while making U-turns, pay due caution if anyone is in the vicinity,
- do not operate the roller on slopes with the inclination exceeding 12° ,
- any repairs, lubrication or cleaning of working components may be performed as long as the engine is not running and the roller is lowered,
- There is a hazard of head injury when you perform maintenance or replacement of parts under the implement without adequate protection - wear a hardhat,
- during a break in the work, always lower the implement to the ground and stop the tractor engine,
- foldable rollers have a mechanical lock that prevents an uncontrolled lowering of the side extensions,
- driving and parking the implement on an unstable slope may cause sliding and soil slipping,
- store the implement in a manner preventing injury to people and animals.

### **3.1. Hitching with the tractor**

- Hitch the implement with the tractor according to the recommendations, use pins and protect the pins with cotter pins.
- While hitching the tractor with the roller, do not stay between the implement and the tractor.
- The tractor used together with the roller must be fully functional and in good working order. Do not attach the implement to a tractor with a defective hydraulic system.
- Remember to observe the following: balance of the tractor and the suspended implement, tractor steerability and braking performance - the front axle load must not drop below 20% of the total tractor load - a kit of front weights.
- In the rest position the implement unhitched from the tractor shall maintain a stable balance.
- The supporting foot should be used on a stable ground. Do not use supporting plates under the foot as this may cause instability of the support.

### **3.2. Hydraulic system**

The hydraulic system operates under high pressure. Take all precautionary measures, in particular:

- do not connect and disconnect hydraulic hoses when the tractor hydraulic system is pressurised (hydraulics set to neutral),
- regularly check the conditions of connections and hydraulic hoses,
- do not use the implement until the hydraulic system is repaired.

### **3.3. Transport on public roads**

Before driving on public roads, fold the lateral sections of knife rollers 4.0H, 5.0H and 6.0H to the travel position using the hydraulic system. Before folding, the machine must be lifted sufficiently high until the folded side sections do not collide with the ground. The knife roller must be protected against unfolding by means of the mechanical lock.

**The clearance under the implement during the drive shall be at least 30 cm.**

While transporting the implement on public roads, it is absolutely mandatory to use lights, an identification sign and reflective side lights.

Do not exceed the maximum travel speeds:

- up to 20 km/h on smooth-surface (asphalt) roads,
- 6-10 km/h on country roads or cobblestones,
- up to 5 km/h on bumpy roads.

Adapt the drive speed to the road conditions to prevent the roller jumping on the three-point hitch and to prevent excessive loads on the implement frame and the three-point hitch.

Act with due caution when passing and overtaking or travelling at curves. The permissible width of the agricultural machinery moving on public roads is 3.0 m.



**WARNING! Any failure to observe the above rules may pose hazard to the operator and other people. It may also result in damaging the machine. The user shall be liable for any damage caused by failure to observe the rules!**

### **3.4. Description of residual risk**

Mandam Sp. z o.o. makes every effort to eliminate the risk of accidents. However, there is some residual risk that may result in an accident. The biggest hazard occurs when/during:

- using the implement for purposes other than described in the manual,
- operating the implement by people who are underage and do not have licences, are ill or intoxicated,
- presence of people and animals within the implement operating range,
- precautionary measures are not taken during transport and manoeuvring with the tractor,
- staying on the implement or between the tractor and the implement when the motor is running,
- maintenance and when the service recommendations are not observed,
- driving on public roads.

### **3.5. Residual risk assessment**

The residual risk can be minimized by applying the following recommendations:

- operate the implement carefully and without undue haste,
- read the instruction manual carefully,
- keep a safe distance from hazard zones,
- do not stay on the implement and within the implement operating range when the engine is running,
- perform the maintenance in accordance with safety rules,
- wear safety clothes and a safety helmet while working under the implement;
- prevent the access of unauthorized personnel and especially children to the implement.

## 4. General information on the use of the implement

Before the machine is put into operation for the first time:

- read the instruction manual,
- make sure that the machine is in proper operating condition,
- check the condition of the hydraulic system (replace damaged components, e.g. pressure hoses),
- make sure that the hydraulic hose quick-connector of the machine match the tractor sockets,
- check the tightening of bolts and nuts,
- check if the air pressure in tyres is according to the manufacturer's recommendations,
- make sure that all components requiring lubrication are lubricated,
- make sure the tyre pressure in the tractor wheels is equal on both axes to ensure even operation.



**WARNING! Do not exceed the maximum permissible axle and tyre loads. The front axle load must not be less than 20% of the total load. Tyre pressure must comply with the values recommended by the manufacturer.**

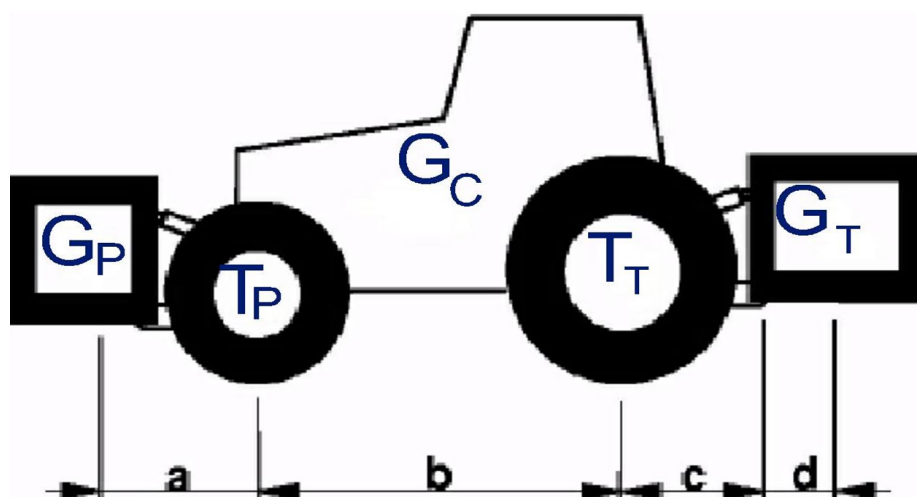

Fig. 6 Diagram with markings of tractor loads.

### Axle load calculations

Key:

$G_C$  - tractor's gross weight,

$T_P$  - front axle load for the unhitched tractor,

$T_T$  - rear axle load for the unhitched tractor,

$G_P$  - total weight of the front-mounted implement,

$G_T$  - total weight of the rear-mounted implement,

$a$  - distance between the centre of gravity of the front-mounted implement and the axle centre,

$b$  - tractor wheelbase,

$c$  - distance between the rear axle centre and the centre point of the hitching pin of the rear-mounted implement,



d - distance of the centre of gravity of the agricultural implement from the hitching pins of the tractor (assume 1.9 m for all widths),  
 x - distance of the centre of gravity from the rear axle (assume 0.45 if the manufacturer does not provide this parameter).

Minimum load at the front in case of a rear-mounted implement:

$$G_{Pmin} = \frac{G_T \cdot (c + d) - T_P \cdot b + 0.2 \cdot G_C \cdot b}{a + b}$$

Minimum load at the rear in case of a front-mounted implement:

$$G_{Tmin} = \frac{G_P \cdot a - T_T \cdot b + x \cdot G_C \cdot b}{b + c + d}$$

Actual load on the front axle:

$$T_{Pcat} = \frac{G_P \cdot (a + b) + T_P \cdot b - G_T \cdot (c + d)}{b}$$

Actual total weight:

$$G_{cat} = G_P + G_C + G_T$$

Actual load on the rear axle:

$$T_{Tcat} = G_{cat} - T_{Pcat}$$

#### 4.1. Hitching the roller with the tractor

Tyre pressure in the tractor wheels must comply with the values recommended by the manufacturer. The lower bars of the three-point hitch should be at the same height, spaced correspondingly to the spacing of the lower points of suspension. While attaching the roller to the tractor, the implement must be placed on hard and even ground.

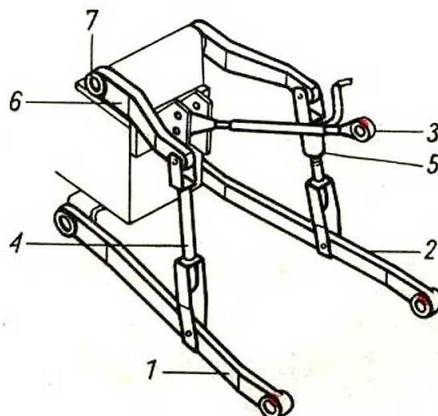

Fig. 7 Three-point hitch of the tractor: 1,2 - lower bars, 3 - upper fastener, 4 - left support rail, 5 - right support rail with adjustable length, 6 - lift arm, 7 - lift shaft

While attaching the roller to the three-point hitch of the tractor, follow the steps as below:

- switch the tractor hydraulic system into adjustment position,

- remove lower hitch bolts (if the tractor lift is not equipped with hooks),
- drive forwards carefully, suspend the implement on the lower bars and secure,
- attach the tractor's upper fastener. During operation of the unit, the hitch point of the upper fastener at the unit must be located higher than the attachment point of this fastener at the tractor,
- check the operation of roller lifting, lowering and the hydraulic system.



**CAUTION!** Hitching the tractor with the roller must be performed carefully, at the tractor's minimum speed! When hitching the implement, make sure that no bystanders are present in the vicinity.

## 4.2. Operation and adjustment

Start working with the roller by making the first trial passage. During this task, check roller adjustment and manner of operation. If necessary, adjust the length of the tractor fastener so that the roller frame is positioned horizontally. The working depth of the knife roller is adjusted by means of the turnbuckles (Fig. 8). The knives should operate on the field surface. The knife roller shall not penetrate into the soil deeper than 2-3 cm. The working speed on the field with the roller attached should not exceed 15 km/h. A correctly hitched and adjusted roller should evenly travel before or behind the tractor and evenly shred the post-harvest residue at its entire working width.

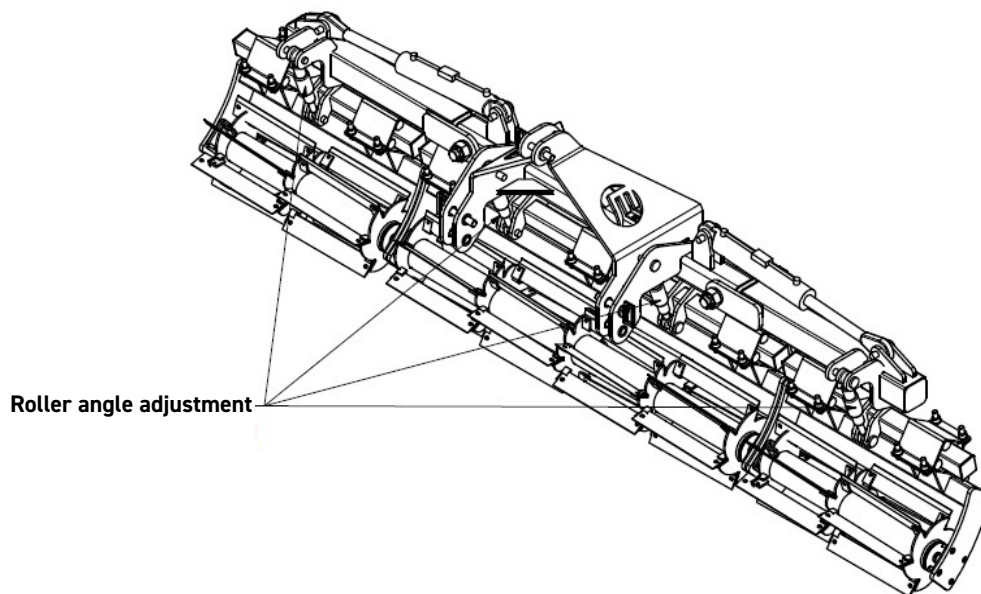

Fig. 8 Knife roller working depth adjustment

### 4.2.1 Setting the knife direction

Tandem knife rollers in 3.0 m, 3.5 m and 4.0 m widths in the non-folding version are factory-prepared for both front- and rear-mounted operation using the tractor's three-point hitch. When attached to the rear three-point hitch, it is possible to suspend an additional unit behind the roller, e.g. a disc harrow. The front three-point hitch adapter should be removed in such case and an additional unit should be attached in its place using bolts.

The Tandem foldable knife rollers in the working width of 4.0, 5.0 and 6.0 are adapted to be attached

to the front three-point hitch. They also feature a floating drawbar stabilized with springs. When the pins are properly interlocked and the working rollers are rotated, it is possible for the roller to work on the tractor's rear hitch.

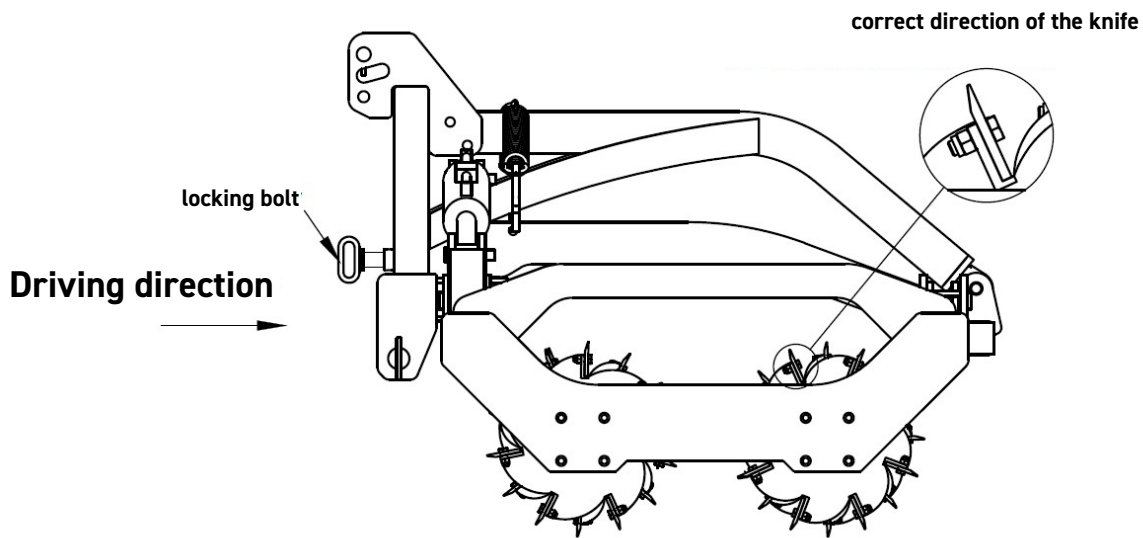

Fig. 9 Setting the tandem knife roller for front hitch operation

In order for the implement to work properly on the rear hitch, the floating position locking bolt must be locked and the rollers must be turned to ensure the correct direction of the knife (Fig. 11).

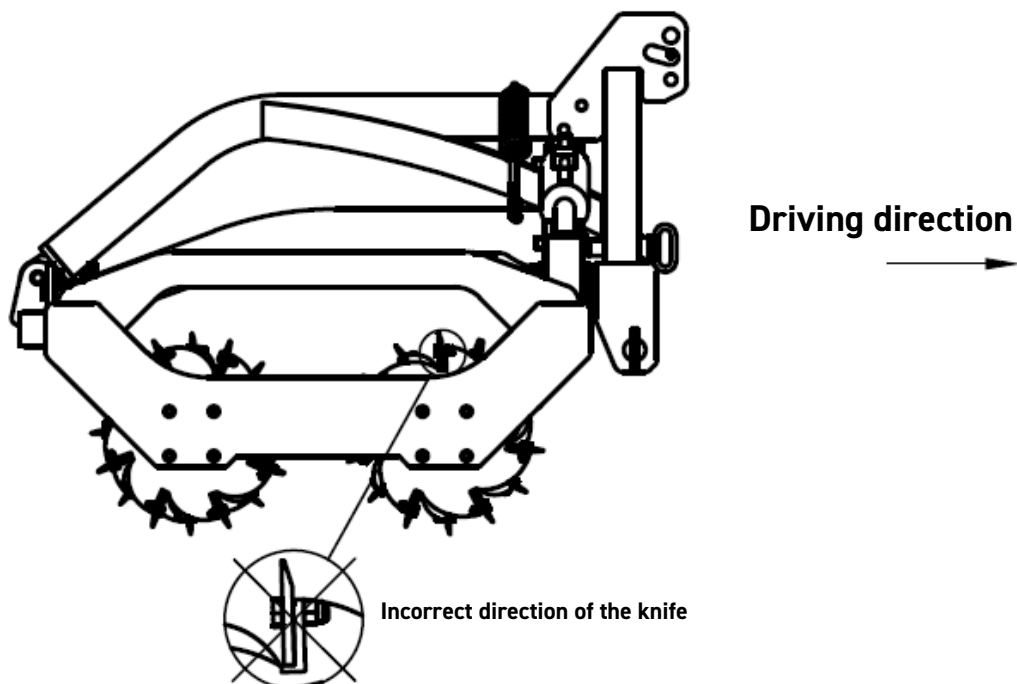

Fig. 10 Incorrect positioning of the tandem knife roller for rear hitch operation

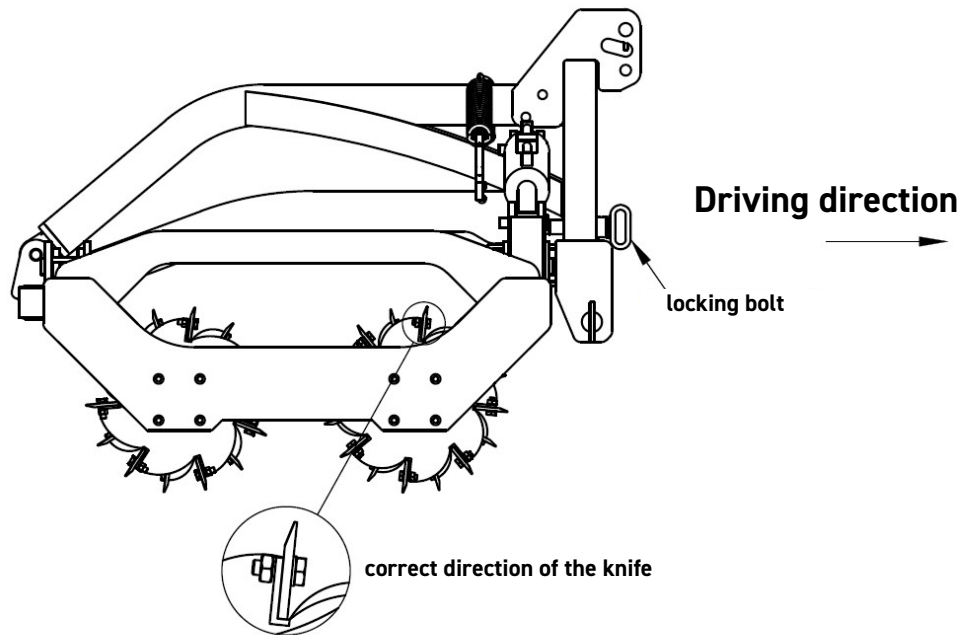

Fig. 11 Correct positioning of the tandem knife roller for rear hitch operation



**CAUTION!** Do not operate the roller on stony soil because the working elements on the roller may become cracked.



**CAUTION!** The knife roller shall not penetrate into the soil deeper than 2-3 cm as this can cause an excessive wear of the roller working parts. The roller should operate on the surface of the field.



**CAUTION!** Folding rollers cannot work on the rear hitch without proper preparation by interlocking the locking pin and rotating the working rollers accordingly.

#### 4.3. Maintenance and lubrication

- Clean the knife roller from soil after each use and inspect the parts and assemblies. **Otherwise, there may be a problem with the folding of the machine if the rollers are clogged with earth and there is an additional load!**
- After the first 4 hours of operation, re-tighten all bolts and periodically check them for tightness. **Failure to do so will exacerbate play and backlash and result in damage to the implement.**
- Lubricate the lubrication points on the hinge bolts daily during the machine's service life.
- Use thread adhesive and only genuine screws and nuts when replacing worn parts.
- Always remember to tighten the screwed joints properly.

**CAUTION! Periodic lubrication guarantees the long service life of the machine.**

The long service life and efficiency of a machine depends to a large extent on regular lubrication. Use mineral greases for lubrication. Clean the lubrication points thoroughly before pressing or applying grease.



**CAUTION! It is forbidden to work on a damaged machine caused by any event resulting in a broken, or deformed frame, roller or other assembly of the machine!**

## 5. Technical maintenance

- After completing the work, lubricate roller bearings, hinges and cylinder bolts (**at least every 10 hours of operation**). For lubrication purposes, the grease of type LT-43 can be used.
- Once the work is completed, the soil residues must be removed from the roller. Check the connections and subassemblies. Tighten any loose screw connections. Replace or refurbish any damaged or worn parts.
- Use only original screws and nuts when replacing worn parts.
- Always remember to tighten the bolt connections properly.
- Replace or refurbish any damaged or worn parts.
- Before a new work season is commenced, always add up the grease in the bearing assemblies.



**CAUTION! During any maintenance work, the roller must rest on the ground. The tractor engine must be stopped.**

### 5.1. Hydraulic system maintenance (knife roller H)

Maintenance of the hydraulic system (Fig. 12) involves visual inspections for its leak tightness. Remember to insert pins into quick-fit connectors. In case of oil leakage from connections of hydraulic hoses, the connector must be tightened. If the oil leakage is not remedied, replace the element or the hose with a new one. If the leakage occurs outside the connector, replace the leaking hose with a new one. Mechanical damage also requires replacement of the subassembly. It is recommended that the hydraulic hoses be replaced every 5 years. If oil appears on the piston rod of the hydraulic cylinder, check for the nature of the leakage. Check the sealing once the piston rod is fully moved out. Minor leakage which results in covering the piston rod with an oil film is acceptable. If the amount of oil is greater or there are oil drops, shut down the unit for the period required to repair the malfunction (defective wiper seal).

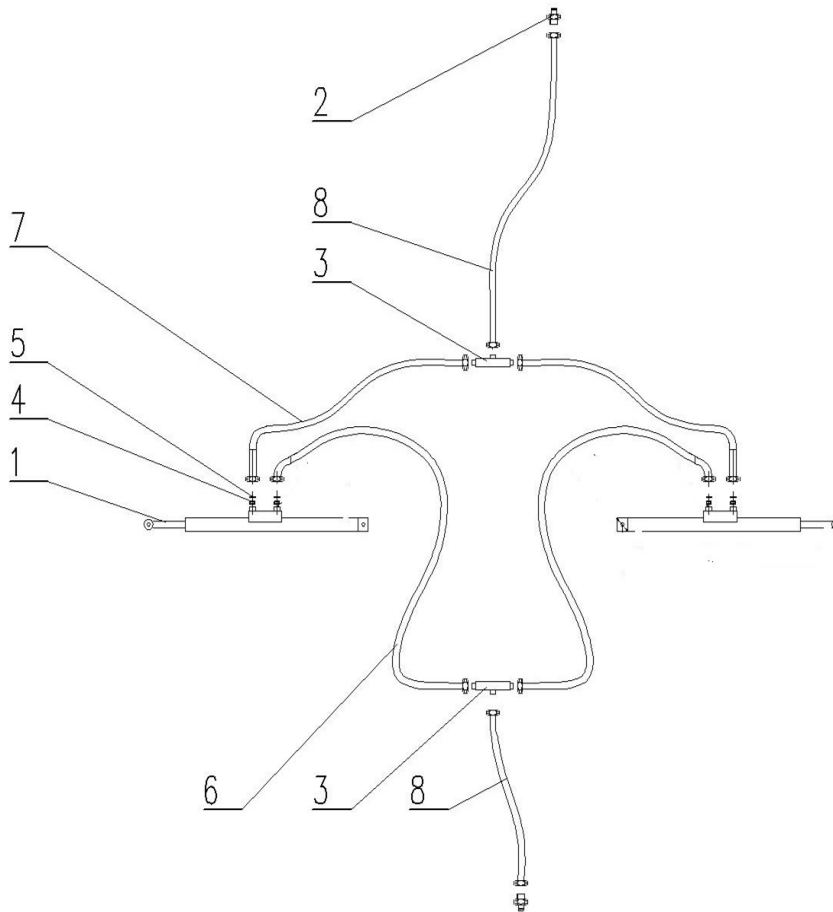

Fig. 12 Hydraulic system on the knife roller 4.0H 1- cylinder, 2- quick-fit connector, 3- T-connector, 4- flange, 5- copper washer, 6,7,8- hydraulic hoses

## 5.2. Defects and malfunctions in the roller operation

As a result of simple design and used materials the rollers have very low failure rate. The durability is increased thanks to the use of knives made of wear-resistant HARDOX steel. Remember that following all guidelines presented in this manual with regard to operation, adjustment, lubrication, transport, and storage considerably contributes to longer trouble-free lifetime.

Damaged cylinders (knife roller 4.0H) shall be sent to a specialist shop for refurbishment or replaced. To re-assemble the cylinder, proceed as follows:

- connect the hoses correctly (as they are connected in the adjacent cylinder),
- first, install and secure the cylinder in the middle frame,
- support the cylinder so that its piston does not collide with any part when it is pulled out,
- perform several working cycles to vent the cylinder (otherwise, the side frame may suddenly collapse, which may result in an accident or implement damage),
- insert the piston rod end into the side section eye and secure with a bolt.

If the components of the machine are disassembled several times, it is necessary to inspect and replace, if necessary, connecting elements such as bolts, washers or nuts, excessive wear of which can lead to uncontrolled loosening of the connected

elements, and consequent damage to them.

Work with extremely worn work tools can cause, for example, roller bearing damage. Tools should be replaced when their wear and tear exceeds the limits allowed by the manual. Otherwise damage may occur, for which the manufacturer **SHALL NOT BE HELD RESPONSIBLE!**



**CAUTION!** During repairs and maintenance, the implement must be lowered on the ground and be resting on supports ensuring full stability. The tractor engine must be stopped. During repairs and maintenance, use proper spanners and safety gloves.

## 6. Roller storage

When the work season is finished, the parts and the sub-units have to be inspected. If any part is found damaged or considerably worn, replace it with a new one. Areas of damaged paint must be cleaned out of dirt and rust. Apply anti-corrosive paint, and then apply a topcoat paint. If possible, store the roller under a roof and protect it against any access of unauthorised persons and animals.



**CAUTION!** When stored, the roller frame must be resting on the support feet. The roller should be set only on a hardened surface.



**CAUTION!** The roller should be stored in a location where it is not hazardous to people and the environment.

## 7. Roller transport

According to the road traffic safety regulations (Regulation of the Minister of Infrastructure of 31 December 2002, Journal of Laws No. 32 of 2002, item 262) - an implement unit consisting of an agricultural tractor and an agricultural implement hitched with the same must meet the requirements identical to those applying to the tractor itself.



**WARNING!** The implement protruding outside the rear side outline of the tractor and obscuring tractor rear lights is a hazard for other vehicles driving on the roads. Be sure to observe the transport instructions specified in chapter 3 General safety information Driving on public roads without adequate marking if forbidden.

The implements must be equipped with:

- triangular board for slow vehicles,
- two boards facing front with a white parking light and a white retroreflector,
- two boards facing rear with composite lamp and a red retroreflector. The plates should be painted in diagonal white and red stripes.

The boards shall be placed on the implement outline, near its edges and shall not extend beyond the 3 m transport width.

The manufacturer does not supply warning plates as standard equipment for the machine. Warning plates are commercially available.

After fixing the plates, connect the electrical cables of the light and signalling device to the tractor's electrical socket.

Always adapt your driving style to the road conditions to avoid accidents and damage to the drive system. Take into account your own skills and traffic intensity, visibility, and weather conditions. Clean the implement from soil residues and check the lights before transporting it. Lift the implement and check the clearance between the lowermost part of the implement and the ground which shall be minimum 30 cm. Be particularly careful during overtaking other vehicles, driving around obstacles and driving through large bumps on the field and dirt roads.



**CAUTION!** Travelling on public roads without warning marks and lights required by law may result in an accident!



**CAUTION!** While transporting the roller attached to the rear-mounted three-point hitch, only tractors equipped with a set of front axle weights are allowed.

## 8. Disassembly and withdrawal from service and scrapping

When operated in accordance with the guidelines in the instruction manual, the implement will have a long life, however worn or damaged parts must be replaced. In case of serious damage (broken and deformed sections), which deteriorates the implement operation and causes a hazard during further use, the implement shall be scrapped. Disassembly of the implement should be carried out by persons who are familiar with its construction. These operations must be performed when the machine is placed on level, firm ground. Start by removing the small parts (bolts, screws, etc.) and proceed to the bigger ones. The implement should be scrapped after complete disassembly and verification of the machine components. During disassembly, group the parts by material type. Waste ferrous metal parts should be grouped together at the collection points for ferrous metals. Dispose of worked oil, rubber pads and hoses as waste and hand them over to the disposal companies.



**CAUTION** *Take all precautions during the disassembly: use appropriate tools and personal protective equipment. Dispose of the disassembled parts in accordance with the environmental protection requirements.*

## 9. Knife roller spare parts

In order to search, find prices and order original spare parts visit our website at [www.mandam.com.pl](http://www.mandam.com.pl), "parts" tab.

There you can find catalogues and spare part sheets in PDF format, containing current part drawings and diagrams for each machine or implement, together with part numbers and prices.



Purchase orders for parts can be placed or enquiries related to the same can be sent directly from this website (tab: "contact/order"), or sent to the following e-mail address: [czeski@mandam.com.pl](mailto:czeski@mandam.com.pl)

A purchase order should contain part numbers and quantities, as well as details of the ordering party/payer together with a contact phone number.

The parts are sent directly to the specified address on the COD basis.

If in doubt, please contact Mandam Spare Parts Department at: +48 32-232-2660 extension 39 or 45 or at + 48 668-66-22-89 (mobile).

Original MANDAM spare parts are also available from all authorised MANDAM distributors.